

## Important notice

Dear Customer,

On 7 February 2017 the former NXP Standard Product business became a new company with the tradename **Nexperia**. Nexperia is an industry leading supplier of Discrete, Logic and PowerMOS semiconductors with its focus on the automotive, industrial, computing, consumer and wearable application markets

In data sheets and application notes which still contain NXP or Philips Semiconductors references, use the references to Nexperia, as shown below.

Instead of <http://www.nxp.com>, <http://www.philips.com/> or <http://www.semiconductors.philips.com/>, use <http://www.nexperia.com>

Instead of [sales.addresses@www.nxp.com](mailto:sales.addresses@www.nxp.com) or [sales.addresses@www.semiconductors.philips.com](mailto:sales.addresses@www.semiconductors.philips.com), use [salesaddresses@nexperia.com](mailto:salesaddresses@nexperia.com) (email)

Replace the copyright notice at the bottom of each page or elsewhere in the document, depending on the version, as shown below:

- © NXP N.V. (year). All rights reserved or © Koninklijke Philips Electronics N.V. (year). All rights reserved

Should be replaced with:

- © **Nexperia B.V. (year). All rights reserved.**

If you have any questions related to the data sheet, please contact our nearest sales office via e-mail or telephone (details via [salesaddresses@nexperia.com](mailto:salesaddresses@nexperia.com)). Thank you for your cooperation and understanding,

Kind regards,

Team Nexperia

**APPLICATION NOTE**

**AN 99040**

**TEA684x FAMILY**

**A NICE RADIO**

**FOR**

**NEW IN CAR**

**ENTERTAINMENT**

**Version 2.0**

### **Abstract**

*The IC **TEA 6840** and its derivative versions **TEA 6845 / 6846** are for small dimensioned Electronic Tuned AM/FM Car Radio receiver in global applications.*

*They carry the following functions:*

- \* AM receiver for long- , medium- and short- wave (up to 49 m) with  
    . noise-blanking and weak signal control.*
- \* FM receiver with
  - . image cancelling on chip;*
  - . world-wide FM- application flexibility;*
  - . keyed AGC;*
  - . weather band included.**
- \* A fast tuning Synthesizer with on chip control for inaudible RDS-AF updating.*
- \* Digital Automatic Alignment for FM- RF circuit and for RF-fieldstrength indication.*

AM and FM operate with high application flexibility, given by peripheral components and by software control via I<sup>2</sup>C-bus.

**TEA684x-Family**  
**A NICE RADIO**  
**FOR**  
**NEW IN CAR ENTERTAINMENT**

**Author(s):**

**Gerrit van Werven, SLE-Eindhoven**  
**Sjakko Sandee , SLE-Eindhoven**

**System Laboratory Eindhoven,**  
**The Netherlands>**

**Keywords**

One chip AM/FM  
Car Radio Receiver  
Integrated FM image rejection  
NICE

With acknowledgements for their valuable contribution to Joop Beunders, Hein van den Heuvel, Kave Kianush, Oswald Moonen, Huub Vereijken and Martin Verheijden from SLE and to Wim van Dooremolen, Analog Advice.

Date: 01 Nov 2004

### Summary

The **TEA 6840H**, in a QFP64 package, is a complete, highly-reliable/small dimensioned, **AM/FM Car Radio** Receiver Module, carrying the following functions:

- \* **AM receiver for LW/MW and SW (31 to 49m)**,  
with double conversion, including
  - > linear AGC, a high dynamic range, using the AM pindiode BAQ 806;
  - > fast level detection;
  - > low distortion detector;
  - > IF-output matched for AM stereo decoding;
  - > a Noise Blanking Circuit at IF;
- \* **FM receiver** for broadcast frequencies 65 to 108 MHz,  
with single conversion, including
  - > image rejection on chip;
  - > digital auto alignment for the RF-tuned circuit;
  - > large AGC range with keyed agc feature;
  - > MPX-output for RDS;
- \* **Weather-band application** 162.4 to 162.55 MHz.
- **Tuning Synthesizer**, using
  - > fast tuning for inaudible RDS a.f.-updating
  - > a VCO with low phase noise, designed for global application;
  - > a reference from a x-tal oscillator, designed for low interference;
  - > using an IF-counter for stop-detection.
- \* **Interface**, matched to nowadays Audio Signal Processors **TEA 6880H (CASP)** and **SAA 7709(CDSP)**
- \* **Bus Transceiver (I<sup>2</sup>C)**, for,
  - > tuning (PLL) and RF auto-alignment;
  - > programmable starting point/ slope for AM/FM fieldstrength detection.

At AM double mixing goes via 10.7MHz to 450 kHz; at FM single conversion to 10.7MHz.

The PLL Synthesizer is designed to have a fast tuning (for RDS AF-updating): < 1msec for a maximum step, going from 87.5 to 108MHz.

Special care has been taken for interference immunity, having the synthesizer on chip with the RF.

Excellent sensitivity figures can be achieved:

at AM, 30% modulation, typ. 50  $\mu$ V (from 15/60pF source) and

at FM,  $\Delta f = \pm 22.5$ kHz, typ. 2.0  $\mu$ V (at 75 Ohm source).

Large signal figures S/N: typ 60 dB at AM (m=30%) and about 65 dB at FM ( $\Delta f = \pm 22.5$ kHz).

High intercept points: At AM is  $IP3 = 130$  dB $\mu$ V<sub>rms</sub> and at FM  $117$  dB $\mu$ V<sub>rms</sub> for "in-band signals".

The peripheral components are limited,

- > using just one x-tal as reference
  - . for 2nd AM conversion,
  - . for Synthesizer reference,
  - . for Audio Signal Processor reference,
  - . for sequential RDS-updating circuitry and
  - . for IF-counter window.

> having wideband AM input (no RF- tuning or -switching);

> with sub-functions for station detection on chip: the fieldstrength level and IF-counting functions.

Performance setting by software gives matching possibilities to regional requirements.

The limited components and the small package has made an AM/FM receiver module for New In Car Entertainment (NICE) with very small dimensions, e.g. 4x9x1cm<sup>3</sup> for TEA 6845 (QFP-package) and 3.5x9x1cm<sup>3</sup> for TEA6846 (LQFP-package); a small module being reliable at low cost.

**Contents**

SUMMARY	4
LIST OF FIGURES	6
1. INTRODUCTION.	7
2. FUNCTIONAL DESCRIPTION	8
3. FEATURES.	9
4. CIRCUIT DESCRIPTION	10
4.1 AM SIGNAL CHANNEL	10
4.1.1 RF INPUT AMPLIFIER	11
4.1.2 AM-MIXERS	14
4.1.3 IF AND DETECTION	15
4.1.4 AM NOISE BLANKING	18
4.1.5 SEARCH STOP INFO	18
4.2 FM SIGNAL CHANNEL	19
4.2.1 RF	19
4.2.2 IF AND DEMODULATION	22
4.2.3 SEARCH STOP INFO	25
4.3 OSCILLATORS	27
4.3.1 VCO	27
4.3.2 X-TAL OSCILLATOR	28
4.4 TUNING SYSTEM	28
4.4.1 DIGITAL AUTOMATIC ALIGNMENT	28
4.4.2 RDS UPDATING	30
4.4.3 ADAPTIVE SYNTHESIZER	31
4.5 I <sup>2</sup> C-BUS CONTROL	33
4.6 SUPPLY	34
5. LAYOUT GUIDELINES	35
6. APPLICATION	36
6.1. AM APPLICATION	36
6.2 FM APPLICATION	38
6.3 GLOBAL APPLICATIONS	39
6.4. OPTIONAL APPLICATIONS	39
Option1. AM- 49m reception	39
Option2. System applications	41
. RDS	
. Weather Band	
. Audio Signal Processing	
6.5. DERIVATIVE PRODUCTS	42
TEA 6845H and TEA 6846H	
APPENDIX 1. I <sup>2</sup> C-BUS DATA	43
APPENDIX 2. ALIGNMENTS	45
APPENDIX 3. a. Module PCB	47
b. Module application diagram	48
c. Components List	49
APPENDIX 4. Module Specification	51
APPENDIX 5. Weather-band receiver	54

**LIST OF FIGURES.**

Fig. 1	TEA 6840H Simplified Blockdiagram	7	
Fig. 2	AM Channel	10	
Fig. 3	AM up/down conversion	11	
Fig. 4	AM RF input amplifier for LW/MW	12	
Fig. 5	AM RF Aerial Filter response	12	
Fig. 6	AM Pin-diode characteristic	13	
Fig. 7	AM RF Bandpass filter	14	
Fig. 8	AM 1st IF selectivity	15	
Fig. 9	AM 2nd IF selectivity	15	
Fig. 10	AM IF and Detection	16	
Fig. 11	AM Level Voltage	17	
Fig. 12	AM Noise Blanking Test Circuit		18
Fig. 13	FM functional Diagram	19	
Fig. 14	FM RF Tuned Bandpass filter	20	
Fig. 15	Quadrature Mixing	20	
Fig. 16	FM Image Cancelling	21	
Fig. 17	Keyed RF-AGC at FM	22	
Fig. 18	FM IF selectivity	23	
Fig. 19	FM Demodulator Output Voltage	24	
Fig. 20	FM-IF Signal and Noise behaviour	25	
Fig. 21	Tuning System	29	
Fig. 22	Inaudible mute behaviour	30	
Fig. 23	RDS AF-check	31	
Fig. 24	Adaptive Synthesizer block diagram		32
Fig. 25	NICE I <sup>2</sup> C Bus	33	
Fig. 26	AM Gain distribution	36	
Fig. 27	AM Signal and Noise behaviour	37	
Fig. 28	AM Intermodulation characteristics	37	
Fig. 29	FM Gain distribution	38	
Fig. 30	FM Signal, Noise and Distortion	38	
Fig. 31	AM LW/MW/SW-49m a 5th order Low Pass Filter	40	
Fig. 32	AM SW - 49m Signal and noise behaviour	40	
Fig. 33	Block-diagram of audio signal processor CASP	41	
Fig. 34	FM Level Voltage	46	
Fig. 35	Module PCB	47	
Fig. 36	FM / AM-MW/LW application	48	

**1. INTRODUCTION**

The **TEA 6840H**, in a QFP64 package, is a complete **AM/FM Car Radio** Receiver Module, called NICE (New In Car Entertainment), carrying the following functions:

- \* **AM receiver**, with double conversion, including
  - > linear AGC, a high dynamic range, using the AM pindiode BAQ 806;
  - > fast level detection and signal detection with low distortion;
  - > IF-output matched for AM stereo decoding;
  - > a Noise Blanking Circuit at IF;
- \* **FM receiver**, with single conversion, including
  - > image rejection;
  - > digital auto alignment for the RF-tuned circuit;
  - > large AGC range with keyed agc feature;
  - > MPX-output for RDS.
- \* **Weather band reception prepared.**
- \* **Interface**, matched to nowadays Audio Signal Processors **TEA 6880H (CASP)** and **SAA 7709 (CDSP)**
- \* **Tuning Synthesizer**, using
  - > fast tuning for inaudible RDS a.f.-updating
  - > a VCO with low phase noise, designed for global application;
  - > a reference from a x-tal oscillator, designed for low interference;
  - > using an IF-counter for stop-detection.
- \* **Bus Transceiver (I<sup>2</sup>C)**, for,
  - > tuning setting (PLL) and RF auto-alignment;
  - > programmable starting point/ slope for AM/FM fieldstrength detection.

The functions are designed for minimum peripheral components, to get a small receiver-module.

Performance setting by software gives matching possibilities to regional requirements.

This report describes the standard application FM and AM/MW based on TEA6840H.

In the Appendix information has been given on derivative versions TEA 6845H/6846H.

**Simplified Block Diagram of the Receiver IC**

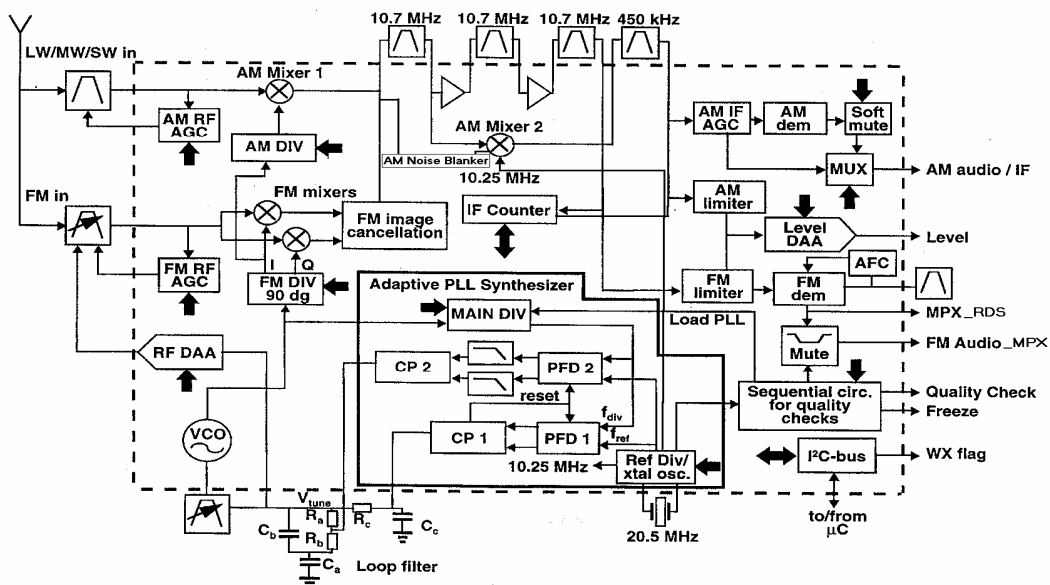

Fig. 1

98011901-



## **2. FUNCTIONAL DESCRIPTION**

To obtain a reliable high performance concept with minimum system price, care has been taken for interference reduction. To that end image rejection is obtained by conversion to a high IF at AM and on-chip image-rejection at FM.

**The AM Section** is a double conversion receiver. The first IF is 10.7MHz, which allows a wideband RF input stage without tracking requirements. The input mixer has a wide dynamic range with a linear AGC. The start of AGC setting is bus programmable by the setmaker. The cost of IF filtering is kept low by a second conversion to 450kHz. The AM IF stage provides soft mute, AM stereo compatibility and a fast stop-level detection. Different antennas (capacitive / ohmic) are possible. An AM noise blanking at IF is included.

**The FM section** utilizes a quadrature- input stage combined with a wide band quadrature phase shift circuit for 30dB internal image rejection at 10.7MHz IF. The input filtering requirements can now be met with a single tuned stage, which reduces the number of external components. The tracking of this tuned circuit is achieved by the RF Digital Automatic Alignment (DAA) block. The linear FM AGC has a programmable start point and offers an optional Keyed-AGC function. The FM channel is prepared for Weather Band application. Both AM and FM level outputs are aligned by bus for start and slope. The alignment coefficients for FM RF tracking and AM/FM level can be stored in a non-volatile memory (e.g. EEPROM) for each individual receiver.

**The VCO** has been defined such that all reception bands can be accessed without any changes to the application. The wideband up-conversion AM input combined with the programmable VCO AM dividers reduce the tuning range such that LW, MW and SW become a continuous band without mechanical switching. The VCO FM dividers bring the required FM frequency ranges - for tuning in Western Europe, Eastern Europe, Japan, USA and Weather Band - to be approximately the same. Therefore one VCO tunes to all bands in the same tuning voltage range.

**The Adaptive PLL Tuning System** combines low phase-noise and low reference spurious breakthrough with a fast tuning response. During FM frequency jumps two charge pumps are active enabling stability and fast tuning to be achieved. After the frequency jump only one pump is active, resulting in a small loop bandwidth and low noise operation of the tuning system. The crystal oscillator operates in a linear-current mode to avoid interferences to the sensitive RF parts. This oscillator generates all the necessary reference signals for the tuning operation and frequency conversions.

**The Mute circuitry.** To provide a better reception, or other information, quality control of other signal channels is used, for example in Radio Data System (R(B)DS) alternative frequency checking. This usually causes audible breaks in the main channel, as the audio signal has to be muted while the receiver is tuning to other frequencies. **Muting actions** are detected in two ways. Gaps in the audio signal may be perceived if the muting time is not short enough. The other mechanism is the distortion of the power spectrum, which is independent of the muting time. In practice, with actual audio signals, muting times below 7ms with gentle slopes of 1ms are inaudible. To achieve FM signal quality checks of 5ms, the tuning times have to be reduced to below 1ms, and the frequency jumps have to be made independent of the slow bus communication times. The first requirement has to be accomplished by the tuning system, whereas the latter was solved by inclusion of 'local intelligence' in the form of **a sequential circuit** that controls tuning operations during quality checks.

**The I2C bus** makes different regional requirements programmable. It has specific building blocks in order to perform inaudible frequency jumps: the sequential circuit, a shaped mute and the adaptive PLL tuning system.

The IC employs **Digital Automatic Alignment** of RF tuned circuit and level signals to avoid mechanical alignments, using pre-aligned coils. This, and the integration of the FM image rejection, the tuning system and the AM double conversion topology, makes the application of NICE simple.

### **3. FEATURES.**

1. **Global Tuner** concept to match on geographical requirements, including Weather Band
2. **Modular**, small dimensioned design with one chip receiver, having few and cheap external components
3. **Compatibility** with both analogue and digital audio processors
4. No mechanical- but **digital- alignment**
5. **High performance** with synthesizer on chip for high immunity and fast tuning
6. **Fast Station detection and quality checking**
7. **Low interferences** with FM image rejection/ AM IF Noise blanking and a linear Xtal-oscillator
8. **Smooth operation** with a.o. inaudible RDS updating
9. **Setmaker's flexibility**, using programmable settings, AM-stereo IF-output etc.
10. **High sensitivity** even at very large signal conditions: high dynamic range
11. **Innovative design towards low price** with
  - . one X-tal oscillator for all reference frequencies.
  - . standard IF-filters
  - . analogue AM-agc with pindiode
  - . FM-demodulator pre-aligned and IC controlled.

**4. CIRCUIT DESCRIPTION;** see Fig.36 for Total Circuit Diagram.

Note: In the description some application info is given in *italic writing*.

The main supply is 8.5 Volt; a 5 Volt supply is used for digital parts and some analogue functions. The external voltages are stabilized, with ripple rejection of > 50 dB at 800 Hz ripple; creating internal reference voltages and currents, taking care for voltage stabilization and temperature compensation.

**4.1 AM-signal channel,**

Main features:

- \* **Antenna** to be capacitive or ohmic (active aerial), as the **AM-RF input is voltage driven**;
- \* The RF-AGC is a plopfree **linear AGC**, using an AM Pin-diode BAQ806;
- \* Care has been taken for interference elimination by band-passing AM-band only (Suppression of FM-intrusion and High-tension mains interferences is possible by input-filtering)
- \* **AM noise blanking** with a noise detector at 1st mixer output and blanking at mixer 2.
- Flexibility by bus-controlled setting of agc threshold.
- Fast station-level detection.

Fig 2 shows the functional AM circuit; full application is given in Fig. 36

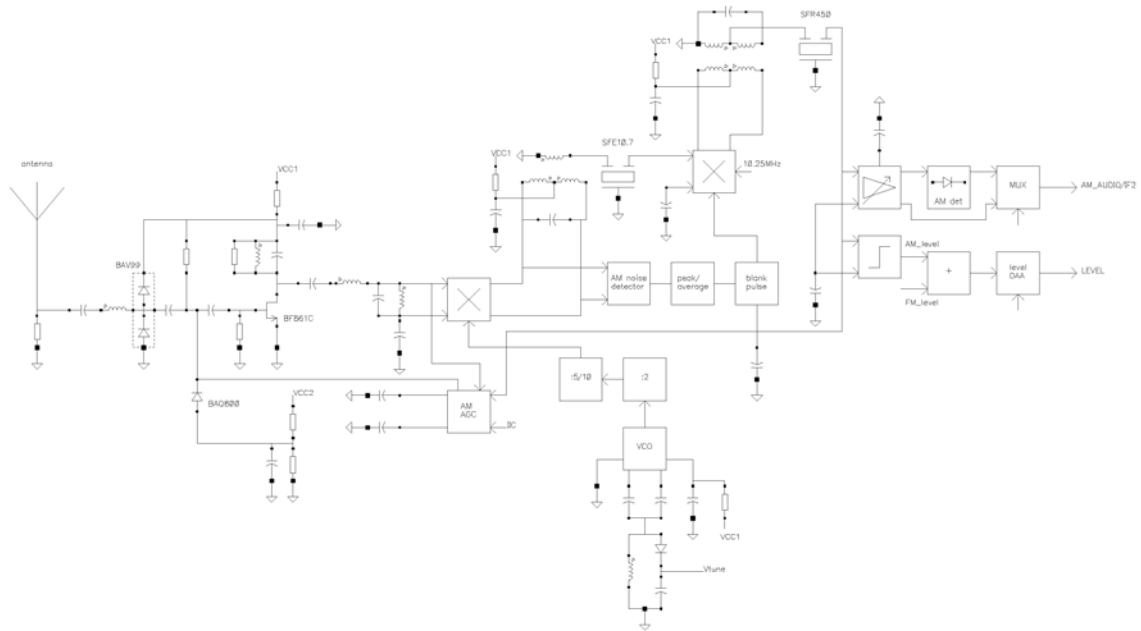

Fig. 2 AM functional diagram of NICE

To avoid RF-selective circuitry for image rejection, or, to permit wideband RF-input, the input frequencies are mixed to a 1st IF\_Frequency of 10.7MHz. By doing so the main image frequencies (image 1 in Fig.3.) are 21.54 to 23.11 MHz, which is so far from the receiving band, that they can be easily suppressed by a Low Pass Filter in front of the 1st Mixer.

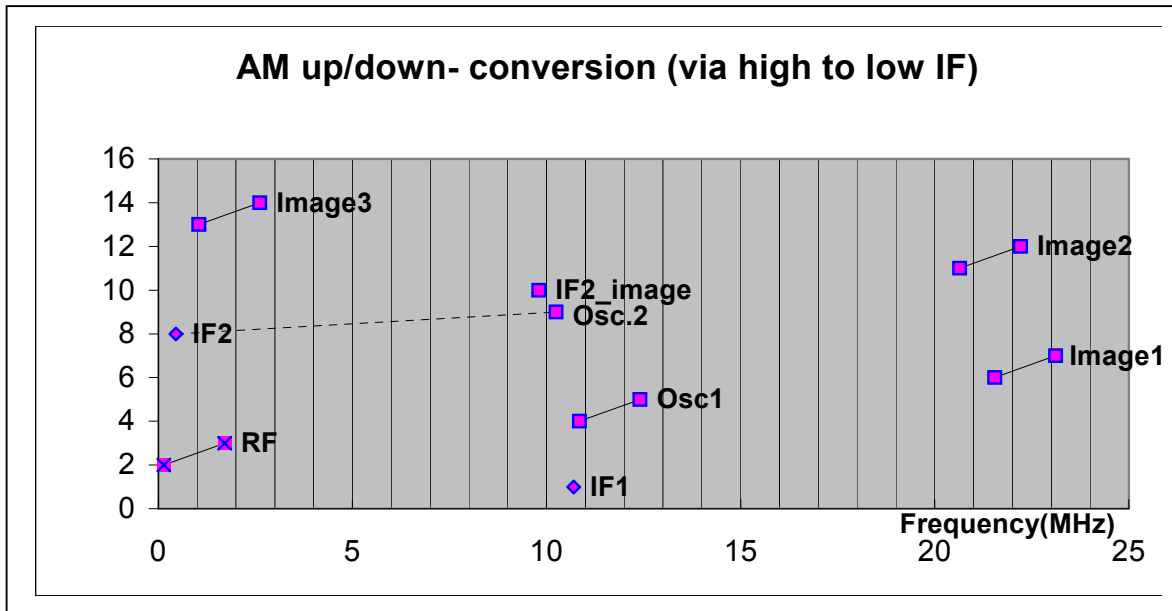

Fig. 3 AM MW/LW conversion via 10.7 MHz to 450 kHz

The 1st IF-freq. (filtered with ceramic filter of 10.7MHz, common used with FM-IF) is mixed down to 450kHz, a standard frequency where a low priced filter take care for channel selectivity before detection takes place. The image frequencies 2 and 3 are caused by this 2nd mixing, as the VCO has transferred these image frequencies to 9.8MHz (here called IF2\_image). This 9.8 MHz will be mixed to 450kHz by the 2nd mixer and therefor 9.8 MHz has to be suppressed in the 10.7 MHz 1st IF filter.

*The suppression at 9,8 MHz in a first IF selectivity acc. to Fig. 8 is about 65 dB.*

#### 4.1.1 RF Input Amplifier

The Aerial input (wideband-) amplifier, shown in Fig. 4, consists of:

- \* an input LC to separate AM from FM,
- \* the FET RF-amplifier using BF862 (or BF 861C),
- \* an RF-AGC amplifier with pindiode BAQ 806;
- \* surge-protection double diode BAV99;
- \* an output AM-bandpass-filter before entering the first mixer.

The aerial is capacitive loaded by about 90 pF, being the sum of  
 .the input capacitance of the FET BF861C (10 pF, but dynamically about 60pF <sup>\*)</sup>;  
 .the zero capacitance of the pin-diode (about 5 pF);  
 .the capacitive input of the FM-RF part (about 15 p) and  
 .parasitic capacitance of aerial-connector and PCB (about 9pF).

*With a capacitive (telescope) antenna, acting at 1MHz as a 15 to 60 pF divider, the total gain loss from dummy aerial input to FET-gate is about 20 dB.*

*<sup>\*)</sup> Note: In cascode-input application this input capacitance is just 12.5 pF (10+2.5 pF).*

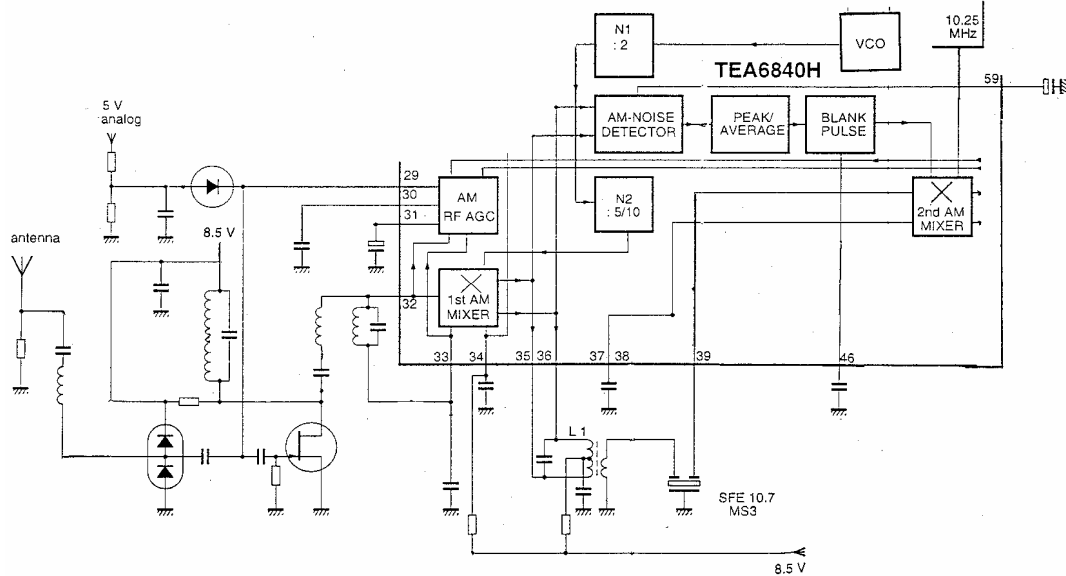

Fig. 4 AM-RF Input Amplifier for LW/MW.

**a. FET-Amplifier:**

The FET BF861C has a low noise of  $1nV/\sqrt{Hz}$  and gives, with its high transconductance, a gain of  $G_m \cdot R_{load} = 25dB$ . Gain control at the gate is linear: without agc-plops and with large signal handling. The concept matches to different antenna characteristics.

*With this FET in the application of Fig.36, the overall AM sensitivity is typ  $V_a = 50 \mu V$  for  $S/N = 26 dB$  (at  $m=0.3$ ), defined with a 15/60pF dummy antenna. A BF862 with 40mA/V transconductance can be used for even more sensitivity (44  $\mu V$ ), with the same gain up to the first mixer.*

*A S/N of 10 dB is reached at an input signal of  $V_a = 9 \mu V$  from a dummy antenna, see Fig. 27.*

**b. Input Filter:**

The input filter takes care for attenuation of undesired frequencies (from FM etc).

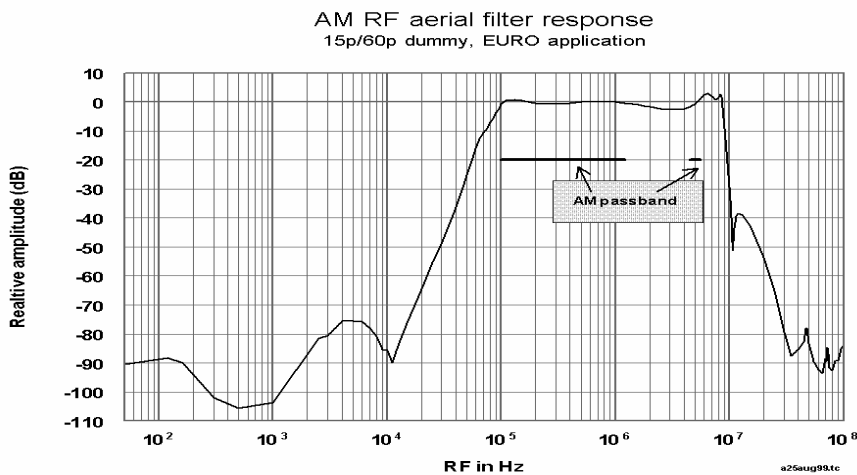

Fig. 5 AM RF Aerial Filter Response

**c. The RF-AGC**

In the TEA6840H IC, the RF-signal at the mixer1 input (pins 32/33) is detected, to build up a RF-AGC voltage available at pins 30 and 31. From pin 29. this signal drives the pindiode with a current up to 15 mA.

A loop C of 220nF (pin 30) takes care for stability.

To avoid harmonic distortion at large in-band signals the signal after the 2nd IF selectivity is detected too to start the RF-agc. This additional IF-detector can start the RF-agc earlier then in case of large 'out-of band signals', such to keep the sensitivity for weak signals as high as possible in the last mentioned situation.

The wide-band agc starting point is programmable via the I<sup>2</sup>C-Bus (2-Bits).

*At out of band large signals the RF-agc starts in TEA 6845H/6846H application at signals with peak level of V32= 125 to 500mV, dependent on bus-setting; for TEA 6840H at 375 to 750 mV.*

*With C= 22 µF at pin 30 and C= 220nF at pin 31 the overall attack time of this AGC is 25msec; decay in 400 msec, switching from 1mV to 1 Volt at AM 990kHz.*

**d. The AM-pin-diode BAQ 806**

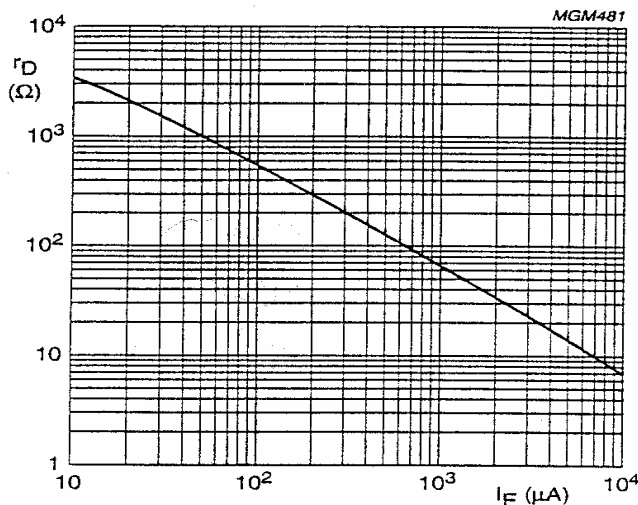

With the BAQ 806 (see Fig. 6), special designed on high linearity, with slow operation for AM frequencies, the RF-signal can be attenuated over a range of about 50dB.

*In the given application IP2 and IP3 values are 140 and 130 dBµV resp.*

*See further the performance of the Module, Appendix 4, in which module diode BAQ806 has been used.*

Fig.6 AM Pin Diode Characteristic: BAQ 806

**e. The Surge protection.**

The high -speed double diode BAV99 protects against static charging at the aerial.

The matching of the two diodes set them each at half the supply voltage to minimise non-linear effects (note that capacitive coupling takes care for a stable dc-midpoint).

**f. The AM-Bandpass filter at the FET-output**

The output signal of the RF-FET has to pass a fixed band pass filter that suppresses the image band before the signal is converted to 10.7 MHz in the first mixer.

In the standard LW/MW-application the low pass filter has a cut-off frequency of 2 MHz, which 4th order filter, see Fig.7, gives > 60dB suppression for images 1 and 2.

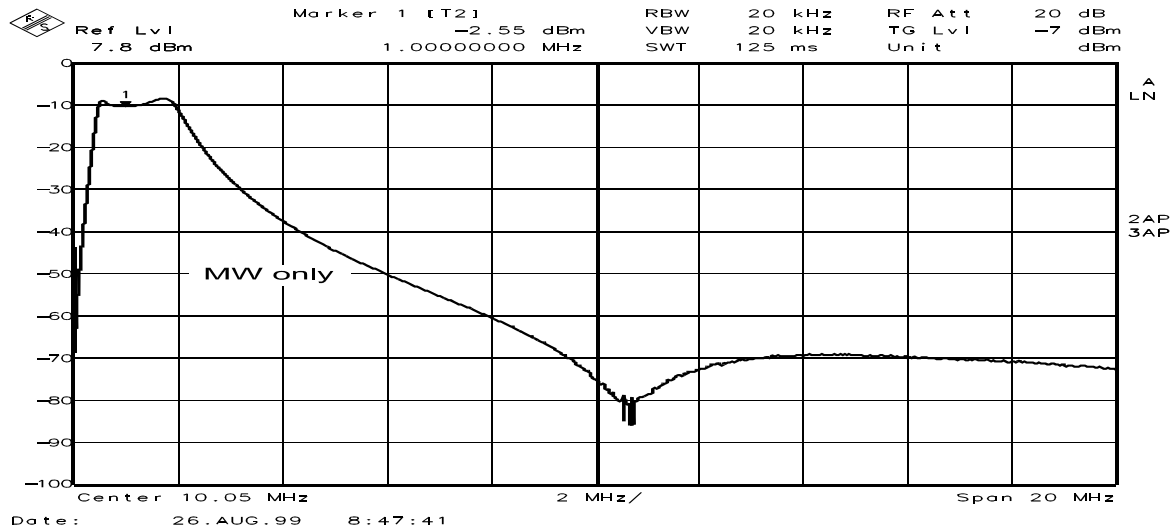

Fig. 7 AM RF Bandpass Filter

For reception of the 49 m-SW-band a filter with cut-off frequency of 6 MHz has to be chosen (see Fig.31)

#### 4.1.2 AM Mixers

\* **The 1st Mixer**, entered at pins 32/33, input resistance about 20 kOhm, mixes the input frequency up to a 1st IF of 10.7MHz. The mixer transconductance is 2.5 mA/V.

To receive MW 530 to 1710 kHz an oscillator- frequency of 11.23 to 12.41MHz is required at the 1st Mixer, to mix to 10.7 MHz.

Important for the mixer is a low noise voltage, being  $6nV/\sqrt{Hz}$ , and low intermodulation (IP3 is about 140 dB $\mu$ V at 2.8 kOhm ac-load at mixer output). The mixer operates at a current of 2x6 mA, having a large signal handling (-1dB compression) of > 500 mV<sub>rms</sub>.

\* **The VCO** (pin 10), delivers the required frequencies via an **Oscillator-Freq.-Divider**, dividing the VCO-frequency by 20 at MW/LW operation; therefor the VCO operates at 224.6 to 248.2 MHz. For SW the division ratio is 10.

It is done in this way to have one VCO for both AM and FM.

\* **The 1st IF-filter**, symmetrical at the mixer-output, pins 35/36, is a tuned LC circuit with a ceramic 10.7MHz filter, common used with FM, having a behaviour as shown in Fig.8.

An LC circuit with  $C= 150 pF$  and  $Q_0= 65$  is loaded by the mixer output impedance of 2.8kOhm. With the 330 Ohm ceramic filter via a coil turn ratio 8 to 2, the gain of given mixer1 is 17 dB, resulting in about 1 dB from mixer1 input to mixer2 input. The choice of turn-ratio is weighted by AM-sensitivity and third order intermodulation, related to the noise and IP3 contribution of the 2nd mixer and detector. (The larger the mixer gain, the better the sensitivity, but at the cost of IP3). Moreover care has to been taken to 9.8 MHz suppression for image rejection.

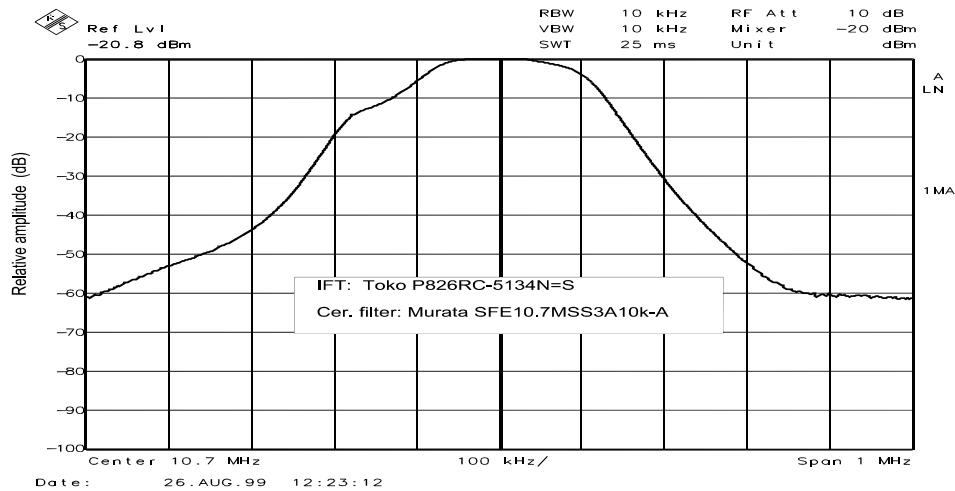

Fig.8 AM 1st IF selectivity

After this 1st IF selectivity, the signal enters the **2nd Mixer** at pins 39/37.

\* The **2nd Mixer** mixes the 1st IF of 10.7 MHz down to 450 kHz with an oscillator signal at 10.25MHz, obtained from a **X-tal Oscillator**. The mixer2 transconductance is 1.6mA/V; the input resistance is 330 Ohm.

At 330 Ohm source its noise voltage is about  $15\text{nV}/\sqrt{\text{Hz}}$ ; biased for  $2 \times 4.5$  mA current. The mixer has a large signal handling (-1dB compression) of  $> 1.1\text{V}$ . IP3 is about 137 dB $\mu\text{V}$  at 1.5 kOhm mixer output load, measured with signals at 50 kHz distance.

**4.1.3 IF and detection**

The Mixer output (pins 52/53) passes a 450 kHz narrow band IF-filter (LC plus a 6\_pole ceramic filter, see Fig.9) and enters **the IF section** (at pin 45 / 48; pin 62 is AM-IF2 ground). Including the losses in the 450 kHz filter, the gain from mixer2 input to IF2 input is 5dB, which makes the gain from input-dummy to IF2 input 11 dB.

*Note: In the given application a SFR 450H filter (6th order) is used, to obtain highest performance as far as cross-modulation and stopband-attenuation is concerned.*

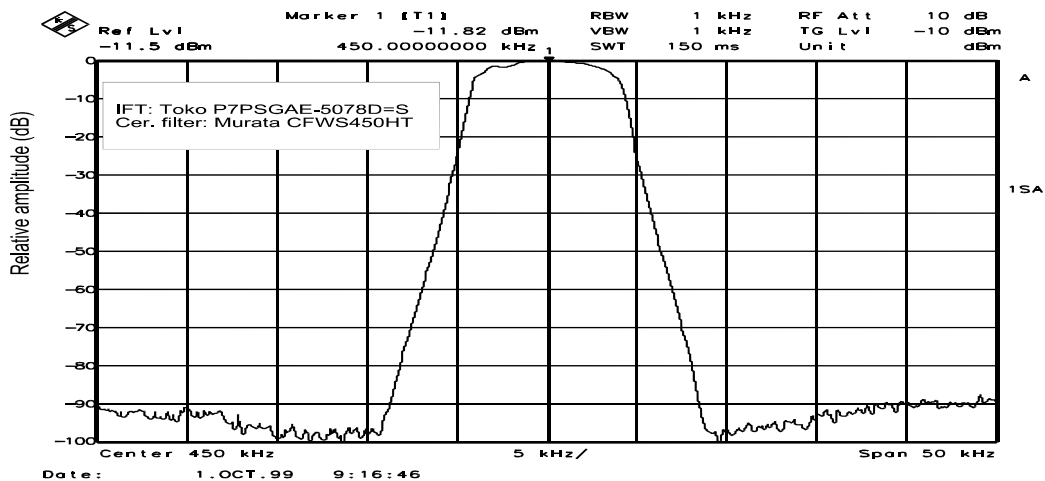
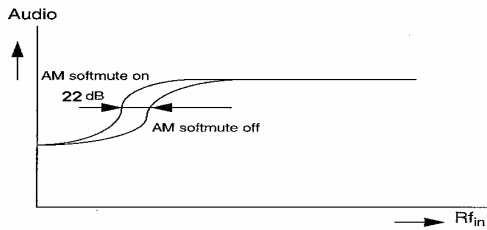

Fig. 9 AM 2nd IF ceramic filter selectivity







**\* Mute**

A mute function at the output of the detector gives a possibility for soft mute setting. Switched by bus, one can change the -10dB audio output from 6  $\mu$ V IF2 input signal towards 75  $\mu$ V. This mute function is driven from the AGC-detector, not from the level detector.

**\* The Level detection**

To obtain fieldstrength information, the level detector delivers dc-information over a signal range of about 20  $\mu$ V to 1 Volt at IF2 input (pins 45-48). The dc-information (see Fig. 11), available at pin 58, is obtained via a second IF-channel (Limiter/ detector), such to have a fast operating level detector. The slope and the starting point can be controlled by Bus for customers' flexibility as well as to match on product-spread; with digital automatic alignment DAA(see Appendix 2). The slope, typical 800mV/20dB, will mostly not be aligned. Special attention has been paid to the temperature compensation of the level info.

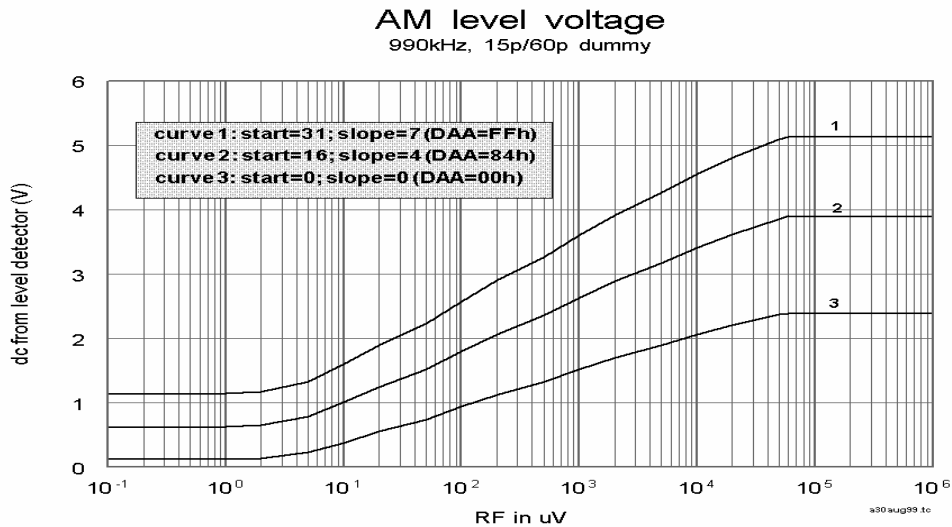

Fig. 11 AM Level Voltage

**\* The AM-stereo info.**

Controlled by the I<sup>2</sup>C-Bus, pin 5 can deliver (instead of mono- a.f. output) a limited, gain controlled, AM-IF2 signal to drive an AM Stereo decoder.

The IF2 output is 180 mV<sub>peak</sub> at V45-48= 5mV, where at pin 5 the output resistance is 500Ohm.

The output is matched to the spec. of an AM-Stereo demodulator, like Motorola MC 13022.

**4.1.4 AM Noise Blanking**

At the output of the first mixer (ignition-) interferences are detected, while blanking is realised in the second mixer. The noise blanker is active only when the (digital-) aligned level voltage at pin 58 is below 2 Volt, corresponding with e.g.  $V_a < 150\mu\text{V}$ . The trigger sensitivity can be modified by changing the voltage at pin 46. A resistor connected from pin 46 to  $V_{CC}$  or to ground (e.g. 68 kOhm) will increase respectively decrease sensitivity. Blanking time typical 7.5  $\mu\text{sec}$  at  $C = 100 \text{ nF}$  at pin 46. In Fig. 12 a definition of interference pulse, as used for testing, has been given. One can switch off this noise blanker with V46 => 2 Volt at the blanker hold -output.

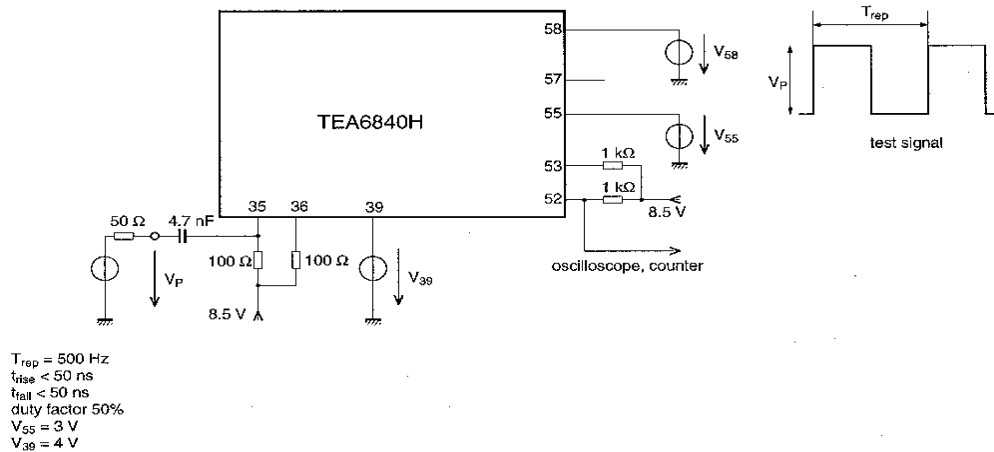

Fig. 12 AM Noise Blanking Test Circuit

**4.1.5 Search -stop information**

For station detection the signal quality is analysed in terms of fieldstrength and IF2 frequency.

At a search the AM the tuning step is 1kHz (at a reference frequency of 20kHz, with the VCO-divider  $M = N1 \cdot N2 = 20$ ).

The IF AGC-amplifier delivers the fieldstrength **level information** analogue to pin 58, to be used in the Car Audio Signal Processor. For this and for the AM-noise blanker triggering the starting point must be aligned with the help of the DAA.

Besides the fieldstrength level, the exactness of the IF can be used for stop-information :

An **IF-counter** counts the 450 kHz IF signal with  $8\mu\text{V}$  sensitivity (at aerial-dummy input for  $m=0\%$ ).

In the AM-mode the counter counts the output signal of the IF-amplifier fast.

The resolution is  $\Delta F_o = 1/t_c = 500 \text{ Hz}$  for  $t_c = 2 \text{ msec}$ .

or  $50 \text{ Hz}$  at  $t_c = 20 \text{ msec}$ ., to be selected by Bus.

The I<sup>2</sup>C-Bus transmits this IF-count information to the  $\mu\text{Computer}$ ; the readout (Hex) is 084H with  $t_c = 2 \text{ ms}$  and 028H at  $t_c = 20 \text{ ms}$ .

**The reference frequency** for the counter **window** is obtained, via **dividers**, from the X-tal oscillator.



filter, having a quality figure Q of about 25, and a transfer characteristic as shown in Fig.14 (measured for the application of Fig.36) is aligned automatically, see chapter 4.4.1

The tuned circuit has an additional rf notch filter, using a printed coil to the midpoint tap of the coil of the parallel tuned circuit. This external notch takes care for >30 dB rejection at all image frequencies.

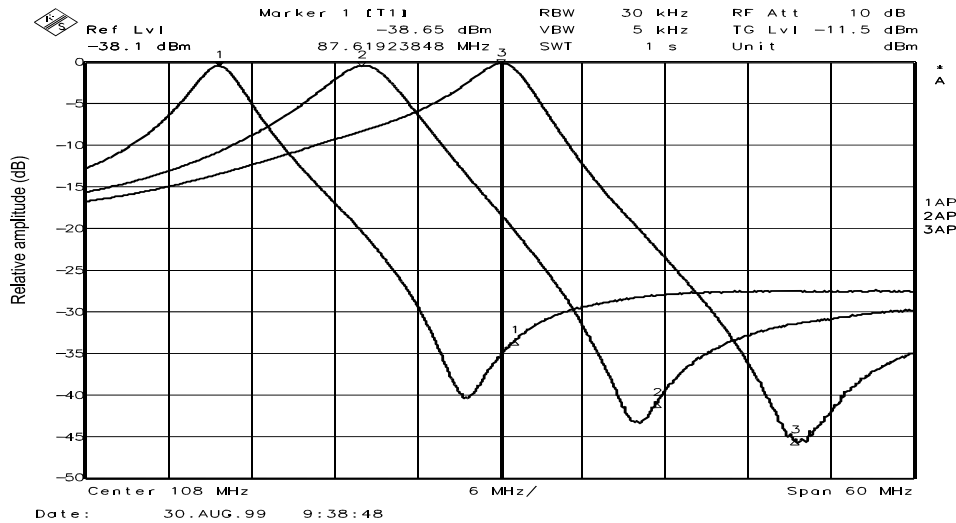

Fig. 14 FM RF Tuned bandpass Filter

**\* Mixer**

The RF-signal, which enters the IC symmetrically at pins 25/27 (pin 26 is the RF-ground), passes the voltage to current converter, the mixer and a quadrature filter block (90° block in Fig.15). The mixer, with a bias current of 12 mA (having optimum source impedance of 200Ω), has a noise figure of 3 dB and a signal handling of 100mV for -1dB compression. Input impedance 2.7kOhm/ 4pF; output >100kOhm. Third order intermodulation IP3 is at 117dBμV. With its conversion transconductance of 12.5mA/V the mixer gain from dummy aerial to the IF transformer input is 33 dB; and 17dB to the 1st IF amp. input. Such with the given 10.7 MHz IF selectivity, which, by the way, has been common used with AM 1st IF.

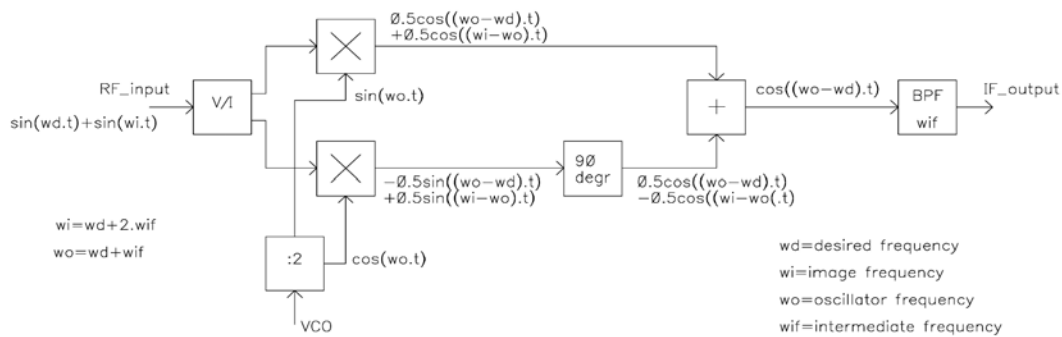

Fig. 15 Quadrature mixing

**\* Image Frequency filtering**

To avoid the necessity of 'High RF-selectivity for image rejection', the image frequencies are suppressed on chip with a quadrature mixer, driven by sin- and cos- oscillator signals. With a 90° phase shifter and adder, Fig.15, image cancellation of 30dB is realised.

*Note: A reference voltage for the Q-mixer is decoupled by 22nF, pin 28; D.C 7.1V at FM (3.6V at AM).*

The oscillator signals are delivered from the VCO via a :2 divider.

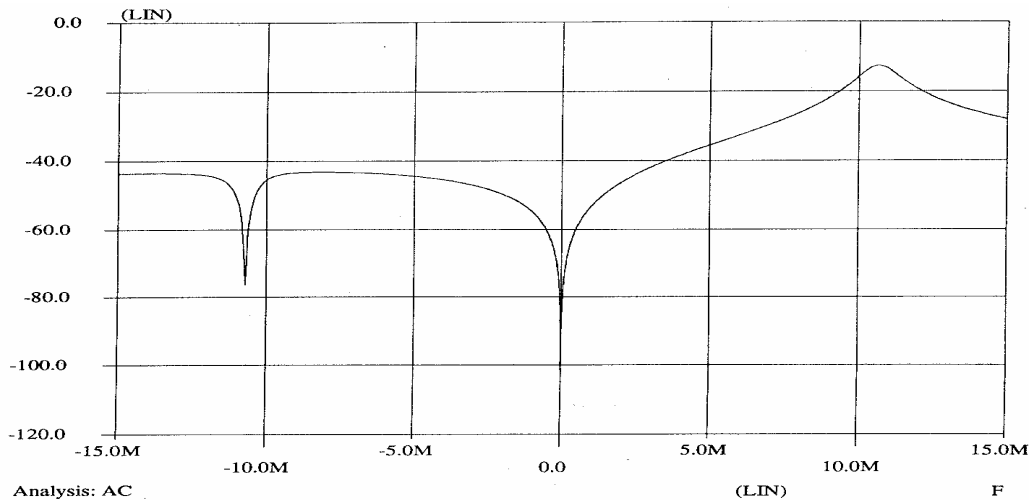

Fig.16 FM image cancelling with quadrature mixer  
(computer simulation)

**\* RF-agc**

The RF-signal at the mixer input has been detected for RF-agc, delivering a current up to 11.5 mA (from pin 24) to control pin-diodes in front of the tuned RF-circuit.

In Fig. 13 two pin diodes have been used in a 3-step control. The IC contains source and sink currents, towards + and – resp.; where the pin-diodes are biased at half the supply voltage. At increasing rf input signal, the series diode starts first with current down control (increasing the coupling impedance to the selective tuned circuit). The 3<sup>rd</sup> step is when series diode control is finished and only the parallel diode gives further damping: up to 50 dB attenuation of the signal to the input circuits. The 2<sup>nd</sup> step is the small in between area.

As this area gives higher requirements on pin-diode linearity, the application of Fig. 36 shows another pin-diode-control. Here only parallel damping is applied with two pin-diodes. The disadvantage of larger signal at the series diode (Fig.13, in the 2<sup>nd</sup> step) has been avoided at the costs of components (a series inductance to maintain rf-selectivity as good as possible). Note that for high stability in the agc loop a series resistor of 22 Ohm at the diode-current output (pin 24) is recommended.

As RF-agc in front of the RF-stage is always a compromise between signal handling and desensitization, therefor the wideband agc starting point can be influenced by Bus (2 bits) e.g. setting starting points at 4 or 8 or 12 or 16 mV<sub>rms</sub> at mixer inputs.

By Bus the FM receiver can be set via this agc in local-mode at standard applications (USA/ Europe/Japan), giving a gain reduction (about 12 dB in Fig.36 application) by 0.5 mA current in the pindiodes. The local-mode can be used for search tuning; tuning to the strongest stations only.

# TEA 6840H A NICE RADIO for New In Car Entertainment

# APPLICATION NOTE AN 99040

In the application, Fig.36, the sensitivity is typ  $V_a = 2 \mu\text{V}$  for  $S/N = 26 \text{ dB}$  ( $\Delta f = \pm 22.5 \text{ kHz}$ ), at input signal (from a 75 Ohm antenna) with 50  $\mu\text{sec}$  de-emphasis.

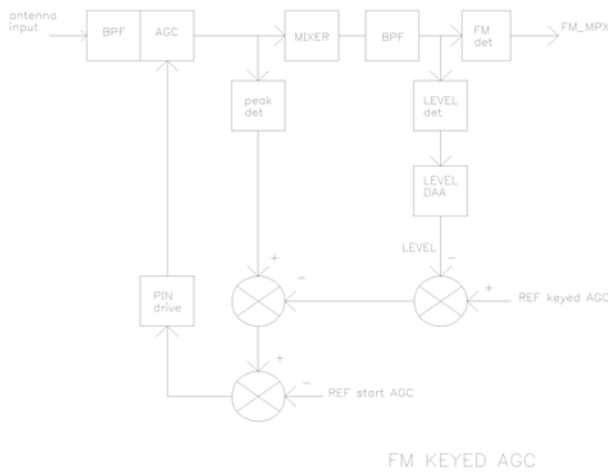

## Keyed AGC

Taking care that RF gain control will be done only if necessary. To that end the amount of agc can be limited with the help of the narrow-band IF-level signal, see Fig.17.

- Influenced by a strong transmitter, the weak signal is reduced till level voltage is decreased to 0.95 Volt, corresponding with about  $3\mu\text{V}$  antenna input signal.
- Then the wideband agc is fixed and larger signals cannot drive the weak signal further into noise (see Fig 17b.).

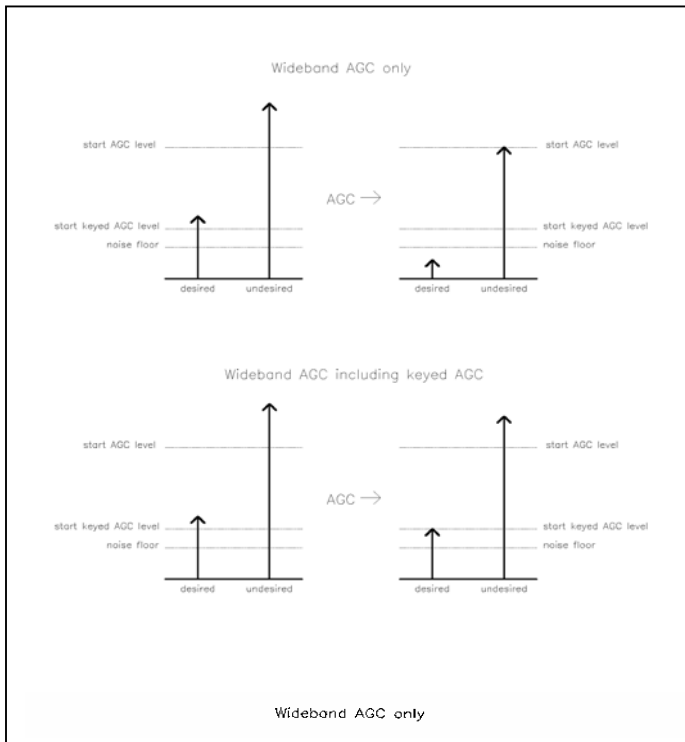

the attack time is 90msec, decay time Fig 17b Wideband AGC

constant 5n

## 4.2.2 IF and demodulation

\* The mixer output signal (pins 35/36) passes a **tuned 10.7 MHz LC-filter and a ceramic SFE filter**, common used with AM-1st-IF, with bandwidth of 180 kHz, and enters the IF at pins 39/37. To minimise coupling with other functions the IF has its own supply pin (38).

\* **The IF selectivity**, is further defined by 2 ceramic filters, in total realising  $S_{200} = >60\text{dB}$ , see curve Fig. 18.

*Note: In the given application SFE10.7MS3 filters\_180 kHz are used. For markets with 200kHz FM-channel grid (in USA or Australia), SFE types with higher bandwidth and lower group-delay variation are recommended. Such to obtain lower distortion at high modulation and improvement on stereo-channel separation without separation adjustment.*

\* **IF amplifiers** are used to compensate filter insertion losses.

They have a high linearity and dynamic range.

The first IF-amplifier has a Gain of 10.5 dB and 300mV input for the -1dB compression point; the second one (input pins 43/41) has a gain of 4.5dB and 600 mV signal handling (on gain compression).

At the input (pins 37/39 and 41/43 resp.) as well as at the output (pins 40 and 47 resp.) the impedances are matched for ceramic filters (330 Ohm).

Noise figures at 330 Ohm source: 9.5dB and 12 dB resp.; third order intermodulation (IP3) at 123 and 132 dB $\mu$ V resp.

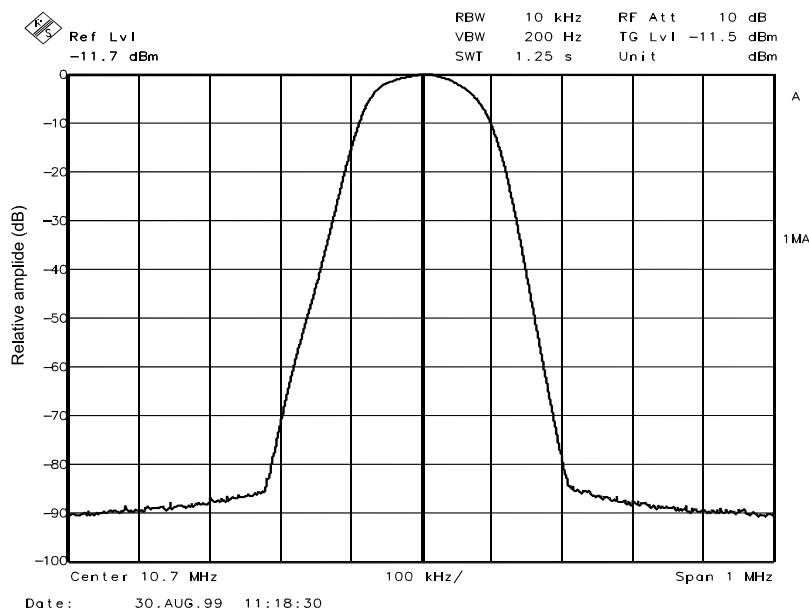

**Fig. 18 FM IF Selectivity**

\* A **limiter** (input pins 49/50) with 80 dB gain, having a -3dB limiting and a  $S/N=26\text{dB}$  sensitivity of both  $V_{49-50} \approx 10 \mu\text{V}$  and 60dB AM-suppression over a signal range of  $V_{49-50} = 0,5 \text{ mV}$  to 300mV, drives the Demodulator.

\* The **Quadrature Demodulator** has a phase shifter which consists of two internal series capacitors of 12 pF and the external demodulator circuit, at pins 60/61, having a coil with a loaded quality factor  $Q_L$  of about 16.



The output voltage of the demodulator versus the frequency deviation from the centre frequency is shown in Fig.19.

The minimum distortion is achieved when the coil is adjusted in that way, that the phase shift at the centre frequency is exactly 90 degrees.

With the parallel resistor of 4.7kOhm, the demodulator can handle modulation up to 150kHz deviation.

**\* AFC of the Demodulator**

Usually the phase shifter has to be adjusted individually because of the tolerances of the components. The TEA6840H has an integrated AFC-function for the FM-demodulator.

The DC-value at the mixer output is an indication for the average deviation of the 90-degree point from the centre frequency. So the DC-voltage can be used to drive an integrated frequency control circuit which automatically adjusts the integrated varicaps parallel to the coil.

Because of this AFC-function an individual adjustment is not necessary, when the coil's parameters are within a specified tolerance range of less than 3% from the specified values. Therefore the circuit can be realised with pre-aligned coils without additional adjustment. The AFC capacitor is connected at pin 59, where  $V_{dc}$  is 3.4 Volt average.

**\* Compensation of Harmonic Distortion**

The demodulator function described is a non-linear function, because the phase shift of the 90-degree phase shifter is not a linear function of the frequency deviation. The difference between the real curve and the ideal curve increases with the deviation from the centre frequency. So the distortion is low for small frequency deviations but increases with the frequency deviation  $\Delta f$ . To improve this behaviour, an additional circuit is used in the demodulator part. It compensates the non-linear function of the demodulator by adding another non-linear function with the opposite characteristic. So, from demodulator point of view, distortion values of about 0.35% can be achieved at modulation  $\Delta f = \pm 75\text{kHz}$ .

\* The **demodulator-output** is available at pin 4 for applications with R(B)DS (Bandwidth >200 kHz at  $R_{load} > 20\text{ kOhm}$ ). This signal, typ. 230 mV, at  $\pm 22.5\text{kHz}$  deviation, is not muted. The **muted FM-MPX** output (230mV at  $\Delta f = \pm 22.5\text{kHz}$ ) is available at pin 3. Mute depth 80 dB; attack- and decay- times are 1msec., in case the mute time constant is set by  $C = 6.8\text{ nF}$  at pin 6.

The IF and limiter signal and noise behaviour from pins 49/50 onwards are shown in Fig.20.

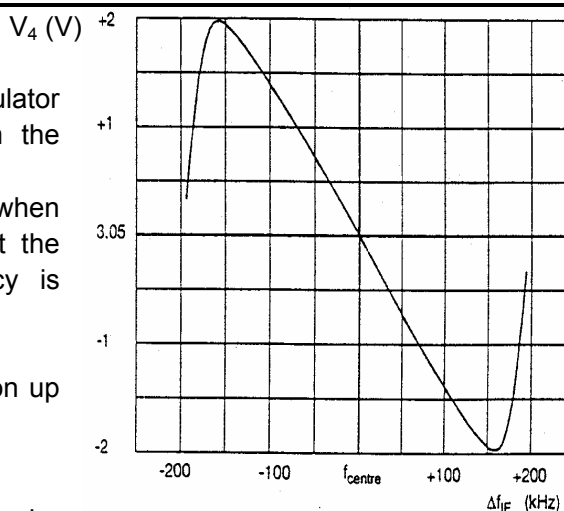
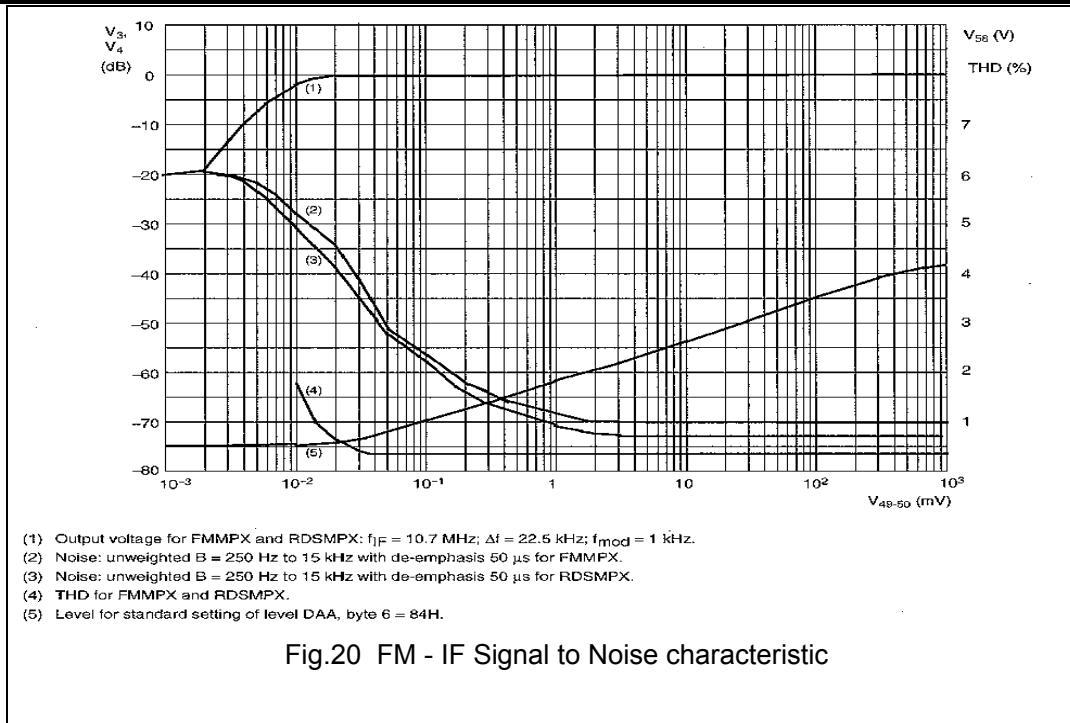

Fig.19 FM Demodulator Output Voltage (V)



At  $\Delta f = \pm 75 \text{ kHz}$  FM-modulation the distortion is typ. 0.35% at  $V_{49-50} = 0.2$  to  $800 \text{ mV}$ .  
 The max. S/N figure of the FM-IF channel at  $V_{49-50} = 10 \text{ mV}$  is  $> 67 \text{ dB}$  for  $\Delta f = \pm 22.5 \text{ kHz}$  modulation.

#### 4.2.3 Search -stop information

At FM tuning steps of 100 kHz, 50 kHz, 25, 20 or 10 kHz can be chosen by Bus (reference frequency setting). With a reference frequency of 100 kHz and the VCO divided by 2, the tuning step is 50 kHz.

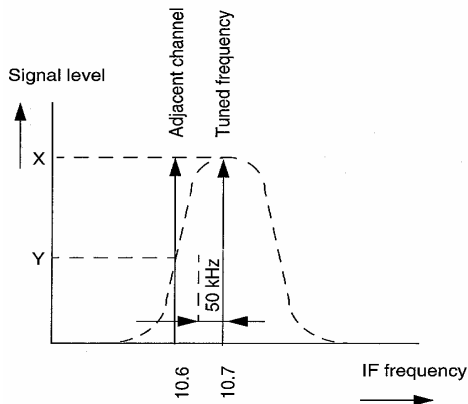

Station quality is detected on 2 items: fieldstrength and IF-accuracy, necessary in areas where the FM-band is crowded, illustrated in the figure.

Appendix 6 gives an example for a basic search tuning algorithm.

##### a. Fieldstrength:

The IF limiter delivers a well defined fieldstrength-dependent DC-level information, analogue available at pin 58, to be used in the audio signal processor

- . for soft mute at weak signal handling
- . for stereo blend
- . for signal dependent response (high cut control etc.).

In a signal range  $V_{49-50}=10 \mu\text{V}$  to 1 Volt the level-detector delivers 4.5 Volt dc. Special attention has been paid to the temperature behaviour of the level amplifier. Over the operating temperature range, the level-change is just as much as  $\pm 2\text{dB}$  RF-signal change.

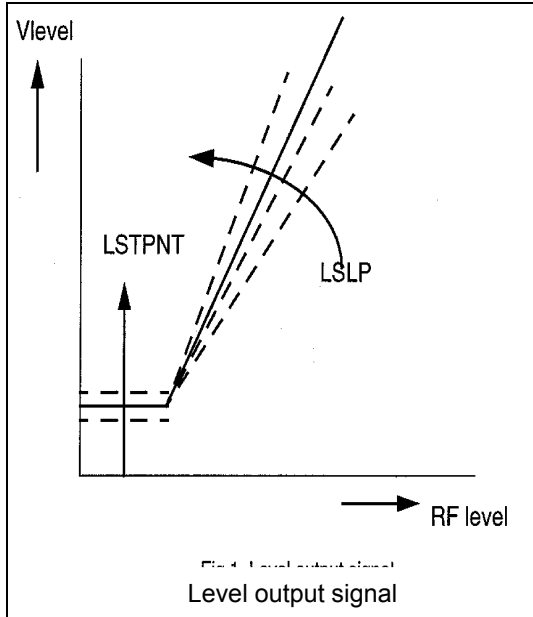

Search stop sensitivity can be adapted with the help of the **Level DAA** such to cope with spread on fieldstrength level information. For production starting point as well as the slope of the level detector need alignments. (Note that level depending parameters, like keyed agc, are influenced).

*Example:*  
 \* *FM level-start:* The level-detector output is set to 950 mV at a RF input level of 3  $\mu\text{V}$ . (Note: 950mV at FM is the switch-off level of keyed AGC).  
 \* *The level-slope is aligned in such a way that the difference in level-detector output between RF levels of 20 and 200  $\mu\text{V}$  is 800mV with the level-start value found in the first alignment.*

*These alignments cannot be seen separately.*

More about alignments in Appendix 2.

**b. IF-Counting:**

Next to the fieldstrength level, the exactness of **the IF frequency** is counted for stop information. To this end the TEA6840H has an 8-bit-IF-counter with a programmable counting window of 2 or 20 ms. The counter counts the output frequency of the limiter amplifier which is divided in a programmable divider, the pre-scaler. For FM the dividing ratio N can be set to 10 or 100. The content of the counter can be read out via the I<sup>2</sup>C-bus. It is not necessary to read out the full value of the IF-frequency to get information about correct tuning. It is sufficient to use only the 8 least significant bits. The counter resolution is given by the counting time and the dividing factor of the pre-scaler.

The number of counted cycle's n, counted during the counting window is

$$n = \frac{F_{if}}{N} \cdot t_c$$

where N is the dividing factor of the pre-scaler and  $F_{if}$  is the output frequency of the IF amplifier. The resolution  $\Delta F_{if}$  of the system is the frequency difference, which corresponds to the least significant bit of the counter(LSB).

$$\Delta F_{if} = \frac{N}{t_c}$$

Next table gives an overview of the possible combinations of read back values and the corresponding resolutions; not only for FM in different markets, but for weather-radio and AM as well.

TABLE IF counter,		read out and IF count resolution		
Application	Tc	IF prescaler	Read out value	Resolution
	(msec)	(N)	(Hex)	(kHz)
FM-standard/-east/-weatherband	2	10	5C	5
FM-standard/-east/-weatherband	2	100	D6	50
FM-standard/-east/-weatherband	20	10	98	0.50
FM-standard/-east/-weatherband	20	100	5C	5
LW / MW / SW	2	1	84	0.5
LW / MW / SW	20	1	28	0.05

The counter sensitivity is high, about 2µV antenna signal for a 30% modulated FM signal.

### 4.3 Oscillators

#### 4.3.1 VCO

The VCO, tunable from 151.2 to 248.2 MHz, serves FM and AM and Weather-band application.

		Divider	VCO	Tuning Voltage	
<b>FM</b>	Europe/USA	87.5 to 108 MHz	2	196.4 to 237.4 MHz	2.3 to 5.5 V
	Japan/Far East	76 to 91 MHz	2	173.4 to 203.4 MHz	1.1 to 2.6 V
	Eastern Europe(OIRT)	64 to 74 MHz	2	149.4 to 169.4 MHz	0.4 to 0.9 V
<b>Weather-band</b>		162.4 to 162.55 MHz	1	173.1 to 173.25 MHz	1.1 to 1.15 V
<b>AM</b>	LW - MW	144 to 1710 KHz	20	216.88 to 248.2 MHz	3.7 to 6.5 V
	SW 31 to 49m	5.9 to 6.2 MHz	10	166 to 169 MHz	0.8 to 0.95 V

**FM** As the **VCO at FM** defines the final S/N ratio at full limited FM-channel, care has been taken to the VCO **Carrier to Noise Ratio**. Therefore a high quality coil ( $Q_0=130$ ) has been used.

For a required  $(S+N)/N = 65$  dB, defined at  $\Delta f = \pm 22.5$  kHz modulation at 50 µsec de-emphasis, the CNR at 10 kHz distance has to be 101 dBc/√Hz for the oscillator signal. The oscillator signal is obtained from the VCO via a :2 divider; so for the VCO a CNR of >95dBc/√Hz at 10 kHz distance is required.

**AM** The target for **AM** is based on avoiding reciprocal mixing by interfering neighbouring ( $\Delta=10$  kHz) signals. With a neighbouring signal 75 dB attenuated and with 5 kHz IF bandwidth the oscillator signal CNR target at 10 kHz distance becomes  $75 + \log 5000 = 112$  dBc/√Hz, delivered from a VCO via 10 times divider (at SW).

So for the VCO  $112-20 = 92$  dBc/√Hz is good enough for AM.

The VCO, common for AM and FM, has a CNR at 10 kHz distance of 97 dBc/√Hz.

#### 4.3.2 X-tal oscillator

The X-tal Oscillator (pins 55-57, with pin 56 for x-tal osc. ground)) operates at 20.5 MHz, having low interferences and using no external components. The oscillator is fully balanced with respect to the crystal pins, such to have low cross-talk towards sensitive receiver pins. The current of the sinusoidal signal at the crystal pins is well defined by internal control to obtain low power/ low harmonics operation. The 5<sup>th</sup> harmonic at 102.5MHz is > 70 dB down. A special circuit takes care for start-up of the oscillator using start-up current of 9mA and an operating current 1.5 mA.

The oscillator is used for **AM second conversion**; for **Synthesizer** Reference frequencies, and to generate clock frequencies for the **Sequential RDS-update circuit** and for **IF-Counter-time-base**. Moreover it delivers (at pin 15) a reference frequency of 75.368 kHz for Car Audio Signal Processors; signal level 100mV from 50kOhm source.

Required is a crystal with the following specification:

- . a motional resistance (at start of operating) of <60 Ohm
- . the shunt capacitance of 3 pF.
- . the load capacitance to be 10 pF
- . motional capacitance 9 fF,

resulting in  $\pm 34$  ppm pulling for  $\pm 1.25$  pF capacitance variation.

Together with the other requirements on

Accuracy	$\pm 20$ ppm
Ageing	$\pm 5$ ppm
Temp. stability	$\pm 30$ ppm,

the application of NICE with this x-tal oscillator permits a worst case max. deviation of  $\pm 1.8$ kHz (which is  $\pm 89$ ppm) from the 20.5 MHz oscillator frequency.

The oscillator gives no contribution to the noise behaviour, as his  $CNR = >101$  dBc $\sqrt{Hz}$  at  $\Delta f=10$ kHz.

#### 4.4. Tuning System

Functional information on the tuning system has been shown in Fig. 21.

##### 4.4.1 The Digital Automatic Alignment

In the application described, the design of the tuned input circuit with capacitance diode BB814 is, in combination with VCO tank-circuit, containing a diode BB156, optimised for low padding deviation by digital automatic alignment. Usually three alignments are necessary and sufficient for a good tracking performance. (Padding max. 400kHz, where the Q of the RF circuit is about 25), to which end the tuning voltage of the oscillator is converted in the DAA to a controlled alignment voltage for the FM antenna circuit.

After having the phase lock loop of the NICE synthesizer locked to a new tuning position, the analogue tuning voltage at the loop filter has been used as reference for RF-tuning.

Starting with a certain input level at the selected input frequency, the level detector output has been measured and stored, where after the DAA value is increased by one. This sequence is repeated for a certain time and from all measured values the maximum value is calculated. When this value is stable for some measurements, the centre is calculated and the corresponding DAA value is stored in the memory (EPROM). This can be done for lower limit-/ upper limit- and mid-frequency of the frequency band.

A "NICE alignment recipe" is available on request.



Next to the minimum leakage currents, low-noise and high ripple rejection, the temperature dependency is an item. As the silicon varactor diode in the VCO is temperature dependent, a compensating diode has been connected at pin 20. This diode is not on chip, such to have its temperature behaviour the same as that of the varactor diode. Temperature drift over  $-40^{\circ}\text{C} < T_{\text{amb}} < 85^{\circ}\text{C}$  is  $< \pm 8\text{mV}$ . The output voltage at pin 21 of the antenna DAA is

$$V_{21} = 2 \times (0.75 \times n/128 + 0.25) \times (V_{19} + V_{20}) - V_{20},$$

in which  $V_{19}$  is the DAA input voltage and  $V_{20}$  depends on the diode connected at pin 20 ( $V_{20}$  is about 0.46 Volt in case a diode has been used).

#### 4.4.2 The RDS updating (Sequential circuit)

To provide best reception quality, a control is used in car radio to check for alternative frequencies with equal programming; such with the help of a system like RDS (Radio Data System). This usually can cause audible breaks in the main channel received, as the audio has to be muted for the moment while the receiver is tuning to other frequencies. Gaps in the audio signal may be perceived if the muting time is not short enough. In practice, with actual audio signals, muting times below 5 msec. with gentle slopes of 1 msec are inaudible, see Fig.22.

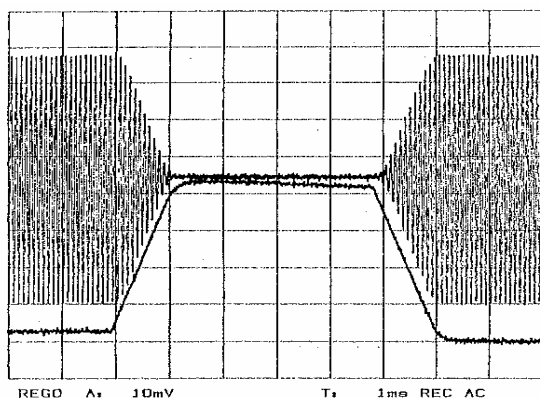

Fig. 22 Inaudible mute behaviour

To achieve FM quality signal checks of 5 msec, the tuning times have to be reduced to below 1 msec. and the frequency jumps have to be made independent of the (slow) bus communication times. The first requirement has to be accomplished by the tuning system, whereas the latter was solved by local intelligence in the form of a sequential circuit that controls tuning operations during quality checks.

This sequential circuit responds on an AF-tag in the frequency word (signifying a quality check request) by

- muting the audio with a 1 msec. slope
- jumping the PLL to another frequency in less than 1 msec.
- sensing the quality of the new signal with the level- and IF-sensors in 2 msec.
- writing this information into latches
- jumping back to the main frequency
- de-muting the audio with the mentioned 1 msec. slope.

## Inaudible Quality Check Control Signals Timing

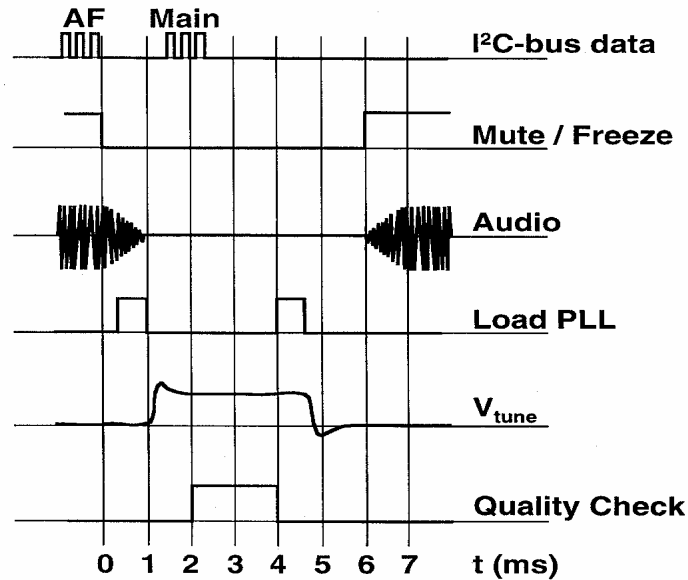

Fig. 23 RDS Alternative Frequency check

A complete cycle (see Fig. 23)

- . starts with a bus command to go to an alternative frequency;
- . next the AF-signal will be muted by reducing the audio-signal linear in 1 msec.;
- . then the tuning voltage jumps due to an in between PLL-load command;
- . after 1 msec. the new tuning position is reached and a quality check (level-info) can be done. For this the counter-period is automatically switched to 2 msec. The prescaler can be chosen freely.
- . then a PLL-load command can start  $V_{tune}$  to jump back to the original main-channel as asked by bus-data.

For application with audio processors (like CASP or CDSP) sample and hold info is available from pins 8 and 7 respectively (Sample- like the 'quality check' and Hold-info like 'mute/freeze in Fig. 23).

The latched info can be read via the I2C bus at any time with simple software (with minimum load of the  $\mu$ controller). Attention has to be paid to the timing of the main-command and the fact that during AF-update no other bus transmissions to the receiver are permitted then those related to frequency and DAA-level. The time constant for mute behaviour at RDS AF update is defined by the capacitor at pin 6. The AF sample and hold flags for the audio signal processors are available at pins 8 and 7 respectively.

### 4.4.3 Adaptive Synthesizer

The tuning system uses a PLL synthesizer, supplied at pin 16 (analogue 8.5 Volt) and at pins 14/13 (digital 5 Volt)

The VCO frequency is divided in a **programmable divider**, controlled by the I<sup>2</sup>C Bus.



The Bus data define the divider ratio of the divider, N, which determines the RF at which the system is tuned.

The divider ratio is

$$N = \frac{F_{VCO}}{F_{ref}}$$

where  $F_{VCO} = M * F_{osc} = M * (F_{tuned} + F_{if})$  with  $F_{if} = 10.7$  MHz both for FM and AM  
M is the divider ratio of the divider N1, which sets the oscillator frequency for the RF-Mixer.  
In next table an overview is given for divider ratio calculation in different applications.

Application	Fif (MHz)	Fref (kHz)	M	Ftune	N
FM-standard	10.70	100	2	76-108	1734-2374
FM-east (OIRT)	10.70	20	2	64-74	7470-8470
FM-weatherband	10.70	25	1	162.4 - 162.55	6924-6930
SW	10.70	10	10	5.85-9.99	16550-20690
LW	10.70	20	20	0.144-0.288	10844-10988
MW	10.70	20	20	0.53-1.71	11230-12410

The divider-output is connected to a **phase detector**, and the divided frequency is compared with the **reference frequency**  $F_{ref}$ . The output of the phase detector drives, via a **charge pump circuit** (output pin 17), the **loop filter** (at pin 18), which in turn delivers the **VCO tuning voltage** (at pin 18).

Spectrum purity, small tuning steps and fast settling times are contradictory requirements for the PLL synthesizer. With the adaptive PLL solution of Figure 24, two loops work in parallel with a smooth take-over to guarantee inaudibility. The phase detector outputs of the Loop-2 are low-pass filtered before the high current charge pump CP2; CP2 is active only during tuning.

Some information in more detail:

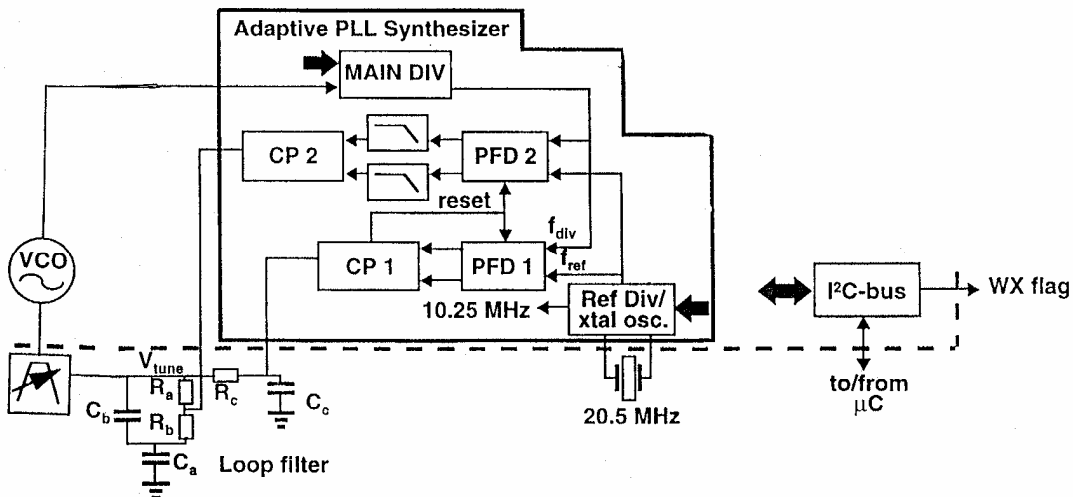

Fig. 24 Adaptive Synthesizer

**\* The charge pump:**

The low-pass filters give a smooth transition into a well defined dead-zone when lock is being achieved. The Loop-1 phase detector has no dead-zone and directly steers the low current charge pump CP1. Good centring of the two charge-pump outputs (by careful symmetrical design etc) is essential for low noise in lock. Additional freedom for optimization of loop parameters is obtained using two separate charge pump outputs, and by applying the charge pump currents to different nodes of the loop filter. During frequency jumps both CP1 and CP2 are active. The loop filter zero frequency is  $[1/2\pi.Rb.Ca]$  and lies at a high frequency, resulting in stability and fast tuning. After the frequency jump only CP1 (to pin 17) is active. The loop filter zero moves, without switching of loop filter components, to a lower frequency  $[1/2\pi.(Ra+Rb).Ca]$ , increasing the phase margin in-lock. Furthermore, when the loop is in-lock, an extra pole is introduced  $[1/2\pi.Rc.Cc]$  increasing the 100kHz reference breakthrough suppression by about 20dB.

To obtain a fast tuning step the charge pump CP2 (pin 18) can deliver 3mA current to the loop filter. After tuning the active charge pump CP1 delivers 130µA at FM to 1mA at AM (Weather-band and East-Europe FM at 300 µA).

*The loop-filter as shown in application, Fig.36, is optimum for fast PLL tuning (< 1msec for a tuning-step 88 to 108 MHz).*

\* The **reference frequency**, delivered by the 20.5 MHz crystal oscillator, can be set by Bus. For fast AF-updating at RDS, PLL control is on chip.

**4.5 I<sup>2</sup>C-Bus control**

**For details: see APPENDIX 1.**

The basic functions and the specification of this bus system are described in a special Philips brochure "The I<sup>2</sup>C-bus and how to use it" (December 1998).

The I<sup>2</sup>C-bus, with clock and data lines at pins 63/64, is structured as shown in Fig. 25.

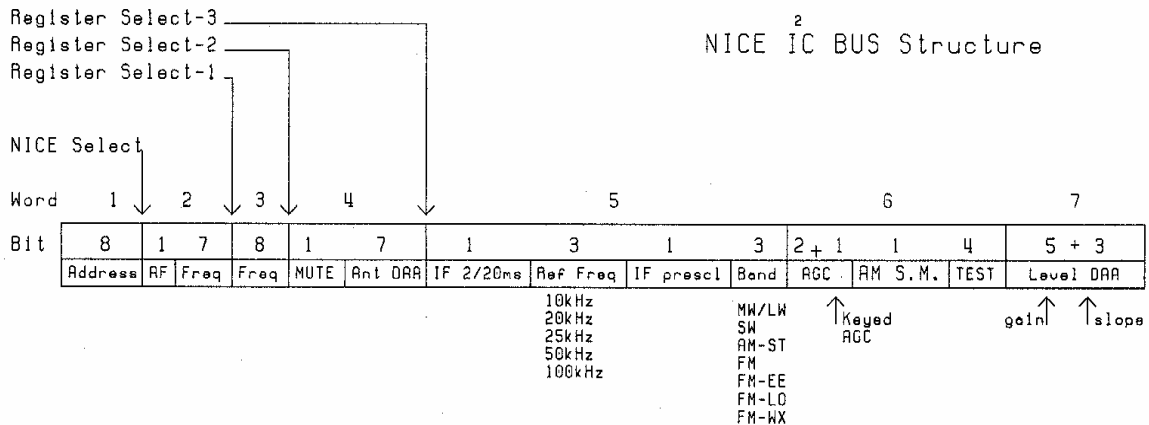

**Fig. 25 I<sup>2</sup>C-Bus structure**

The bus communication starts with a "start"-signal given by the system controller. The first transmitted byte is the address byte. The following bytes are used to transmit information to

the IC or to receive information from the IC. When the bus communication is used partially the transmission must be ended by a stop condition. In this case the remaining bytes will contain the old information.

The complete information to set the IC TEA6840H consists of the address byte and six data bytes. The address byte is 1100001R/W.

Commands received are for

. AM/FM-switching	on/off
. Programmable Divider	15 bits
. DAA setting	7 bits
. Local Distance switch	on/off
. Synthesizer Reference Frequency setting	10/20/25/50/100 kHz
. AM Oscillator-Divider N2 setting	:5 / :10
. IF-count time	2 / 20 msec
. IF counter prescaler rate	100/ 10
. RDS update start	
. FM_Audio mute switch	on/off ( <i>additional function load PLL</i> )
. AM soft-mute switch	on/off
. RF AGC threshold	2 bits
. FM Keyed AGC switch	on/off
. Level slope setting	3 bits
. Level starting point setting	5 bits
. Weather band switch	
. Testing reference frequency and divider and DAA's	4bits

Commands transmitted by TEA6840H

. IF-counter information	8 bits.
--------------------------	---------

#### **4.6 Supply**

The main **supply is 8.5 Volt** , which has to deliver typical 56 mA at FM and 49 mA at AM. In addition **5 Volt supply** is needed at pins 14/13 for digital functions using 23 mA current consumption; and at pin 2 for analogue functions with 8.1 and 5.9 mA current at FM and AM respectively.

The external voltages, having ripple rejection >40dB at 800Hz ripple (by external components) create internal reference voltages and currents, taking care for the required stabilization and temp. behaviour.

*Notes :*

- . *Stabilised supply IC's has to deliver 8.5Volt with >50dB ripple rejection at 800Hz.*
- . *Care has to be taken for a good ripple rejection of the VCO-supply (pins 9 and 12).*

## 5. LAYOUT GUIDELINES

Application of the TEA 6840H simplifies the PCB design of a digital tuned AM/FM receiver dramatically. To minimize the design costs, the digital tuning function and the analogue receiver parts have been integrated on one IC and furthermore special measures have been taken during the IC design. (Like good internal separation of the analogue and digital parts in order to minimize interferences.)

Because of these measures, the PCB given in this Application Note (see Figure 33) is rather simple and a large list of layout tips is no longer necessary. However, being a radio application in which the gain in several parts of the receiver is considerably high and where RF and oscillator signals should not enter the final IF stages etc. still some attention has to be spend on the PCB design. When the layout, given in this application note, is used, problems are not to be expected (see Appendix 3 for a two-sided PCB, version TEA 6846).

*Nevertheless some layout tips are:*

### **VCO:**

*The VCO coil needs to be put close to the IC pins, also the grounding of the VCO varactor diode (BB156) via the 270pF capacitor (C63, high Q; NP0) and the grounding of VCO coil needs to be done directly to the VCO-GND pin 48.*

### **FM-Mixer:**

*The connection of the FM input transformer (L10) to the mixer pins (FMMIXIN) should have the same length. The first FM PIN diode (D3) and its de-coupling capacitor need to be put close to the antenna connection to prevent large signals from entering the PCB. The PIN diode decoupling capacitors of 1nF (C37 + C38) need to be of the NP0 type. These are unfortunately 0805 SMD's but the 0603 version is of the X7R type; an X7R capacitor has very poor performance on 100MHz so gives very poor AGC behaviour. The two SMT coils (L11 + L12) in the FM input circuit need to have a high Q at FM.*

### **Tuned coil:**

*With our tuned coil and with its tap chosen we have the SLINE coil is about 20 – 30 nH. This coil can be replaced by an SMT version; this will increase the component bill but that way finding the optimum value will cost you some PCB designs. The Q of this coil is not very critical as long as the image suppression is about 30 dB.*

### **AM:**

*The FM intrusion trap (L3 + C4) needs to be placed close to the antenna connection.*

### **Reference crystal:**

*The 20.5MHz crystal can best be put close to the IC-pins.*

### **I<sup>2</sup>C-Bus tracks:**

*To suppress I<sup>2</sup>C-Bus interferences we have put 330 Ohm resistors in the SCL and SDA lines. Further it is important to keep these tracks away from the demodulator coil and from the VCO coil and its tracks connecting it to the IC pins. We also use a filter in the I<sup>2</sup>C-Bus outputs of the embedded micro-controller to round-off the I<sup>2</sup>C-Bus pulses a little.*

**6. APPLICATION.**

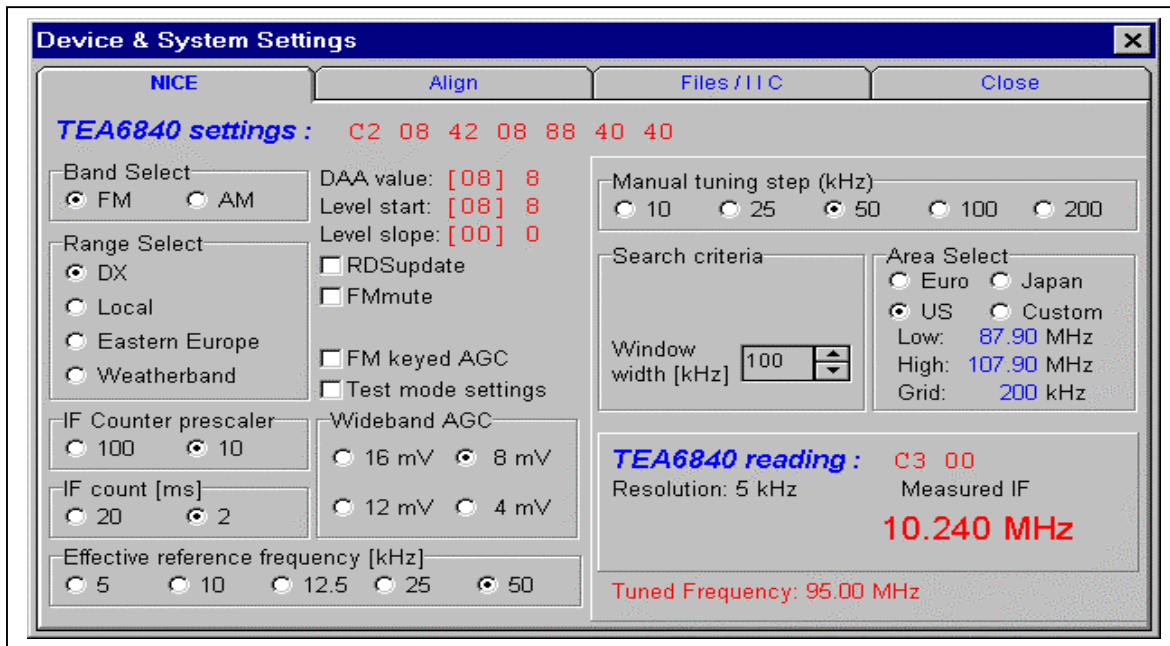

**6.1. Application AM**

For the Module TEA6840H (Fig.33, application acc. Fig.36) the **Gain** distribution in the AM-channel is as shown in Fig. 26.

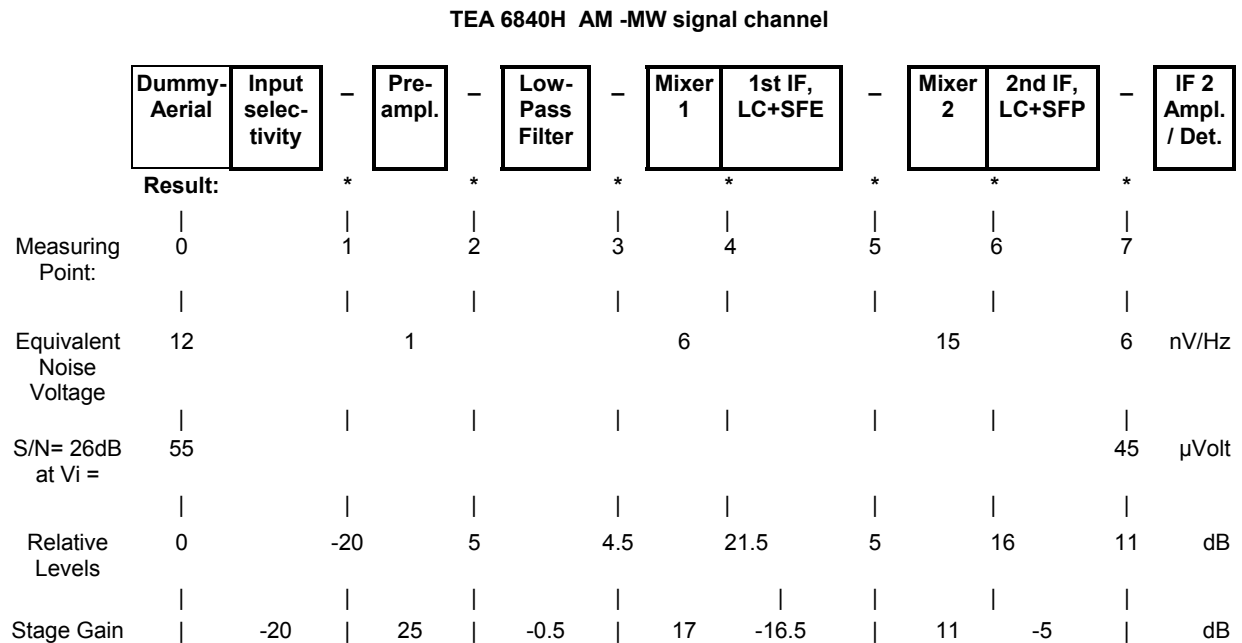

Fig.26 AM Gain Distribution

# TEA 6840H A NICE RADIO for New In Car Entertainment

# APPLICATION NOTE AN 99040

Fig. 27 shows **MW Signal and Noise** behaviour as a function of fieldstrength with selectivity acc. to Fig.5, 7, 8 and 9; the THD-(Total Harmonic Distortion) behaviour is given too.

The noise limited **Sensitivity**:  $S/N=26\text{dB}$  at standard modulation

Dummy-antenna at loaded generator	$S/N = 26\text{ dB}$ at $V_a =$
15 to 80 pF	68 $\mu\text{V}$
15 to 60 pF	55 $\mu\text{V}$
27 to 47 pF	34 $\mu\text{V}$
50 Ohm	3.6 $\mu\text{V}$

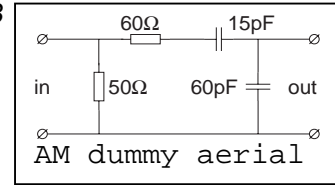

This sensitivity is constant over the MW band. At LW the value is a higher: 110  $\mu\text{V}$ . In case lower inter-station noise is required (or lower Figure Of Merit), one can reduce gain, switching on the AM soft mute function, see curve 2. in Fig. 27.

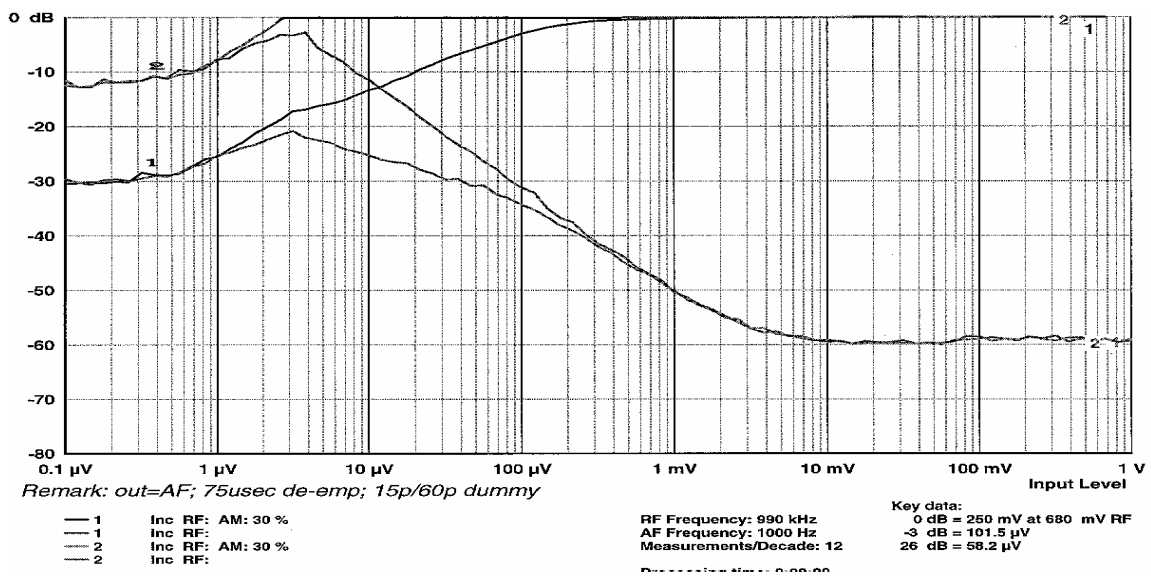

Fig. 27 AM Signal and Noise behaviour

**Intermodulation**: Sum and difference freq. reception of 2 strong signals; combinations of freq. cause IP3, cross-modulation related 3rd order non-linearity. The Intermodulation Points: see Fig.28, with IP2 caused by 600 and 800kHz at 1400kHz tuning and IP3 caused by 1040 and 1090 kHz at 990 kHz tuning; as a function of the input voltage at the dummy aerial.

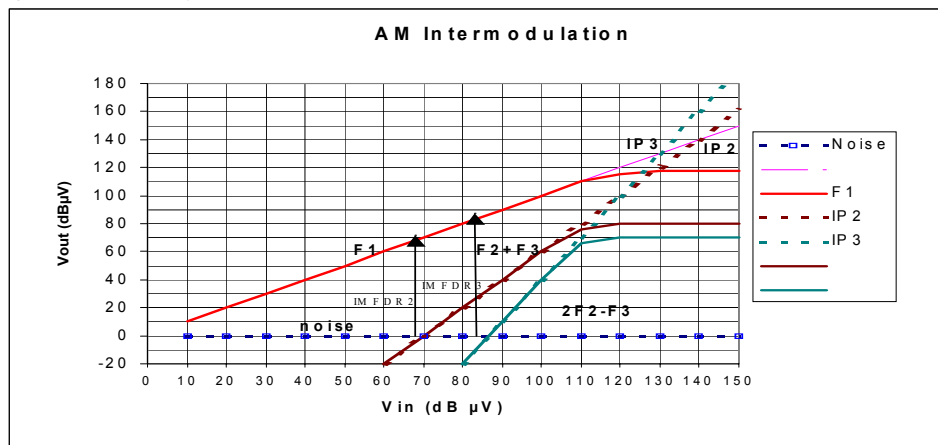

Fig. 28 AM Intermodulation characteristic

**6.2. Application FM.**

For the given application the **FM-Gain Distribution** is :

	Dummy-Aerial	Input selectivity	Transformer	Mixer	1st IF, LC+SFE	IF-ampl 1	2nd IF, SFE	IF-ampl 2	3rd IF, SFE	Limiter / Demod.
Measuring Point:	0			1	2	3	4	5	6	7
Noise Figure	6			3			9.5		12	
S/N= 26dB at Vi =	2.1									10
-1dB Compression				100			>300		>600	
IP3				119			123		132	
Relative Levels	0			1	33	16.5	27	22.5	27	22.5
Stage Gain				32	-16.5		10.5	-4.5	4.5	-4.5

Fig. 29 FM Gain Distribution

Fig. 30 shows **Signal, Noise and SINAD characteristics / Total Harmonic distortion and AM-Suppression and level-information** in this application (with selectivity acc. to Fig. 21).

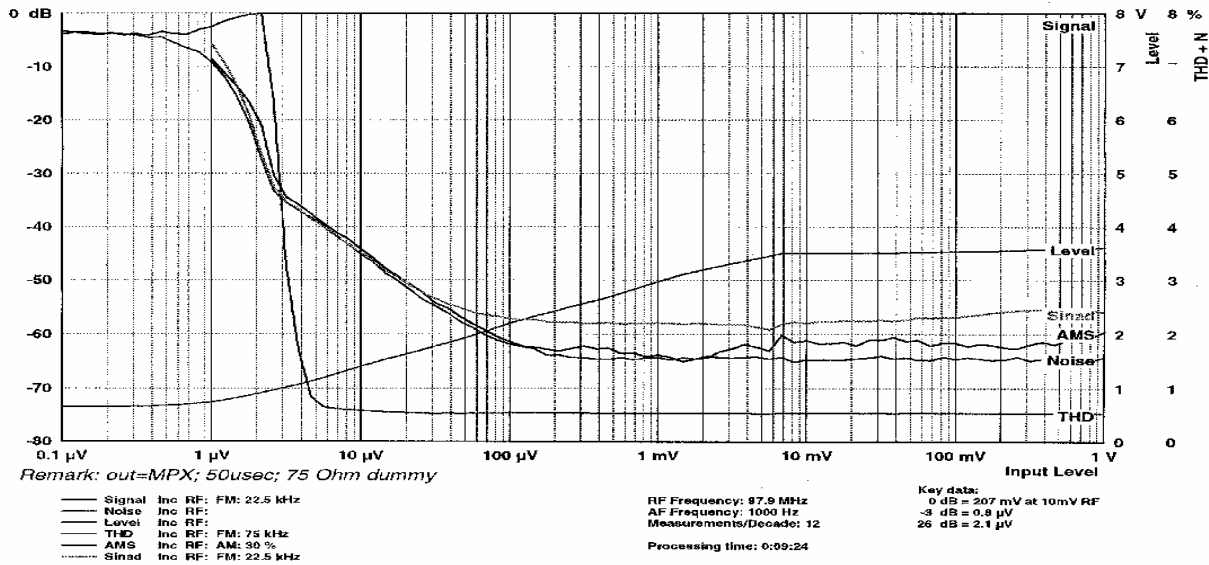

Fig.30 FM Signal, Noise and Distortion

$R_{\text{antenna}}$	-3dB Limiting at $V_a$	S/N = 26 dB at $V_a$	
75 Ohm	1 $\mu$ V	2.1 $\mu$ V	

75  $\Omega$  FM-dummy aerial

**6.3 Global Applications :**

**1. Europe:** Standard application;

FM-band 87.5 to 108 MHz , channel grid 100 kHz, de-emphasis 50  $\mu$ sec

AM-LW 144 to 288 kHz

MW 522 to 1620 kHz , channel grid 9kHz

**2. USA**

FM-Band 87.9 to 107.9 MHz , channel grid 200 kHz, de-emphasis 75  $\mu$ sec

AM-Band 530 to 1710 kHz , channel grid 10 kHz.

Some items, characteristic for USA applications, influencing choice of components:

- a. Higher channel grids permit the use of wider IF-selectivity (*SFE's 180/180/220 kHz*); and wider FM IF-selectivity gives good Stereo channel-separation without adjustment
- b. De-emphasis-C's to be matched to USA situation (*75 instead of 50  $\mu$ sec.*); to be done by software setting in the audio processor (CDSP or CASP).
- c. FM-broadcast transmitters located at one position (city) can have low freq. difference, asking special attention for certain intermod. suppression and AM-interference breakthrough.

*Note: To reduce FM intrusion e.g. for USA-markets, where two FM-transmitters F1 and F2 can have freq. difference  $|F1-F2|$  which can fall inside an AM-band, a special filter can be designed to block the FM frequencies.*

*With such a filter included, 2 FM-signals having 800kHz freq. offset, need to deliver 450mV aerial input level, before they give, at 800kHz AM-tuning, an audio-interference of 20dB below standard (30%modulated) AM a.f. output.*

Other signals to be attenuated at the AM-input are **mains-interferences** from high-tension wires and ultra-sonor signals (used at deep-sea research). These signals can be suppressed by the input filter, defined by coupling capacitance  $C= 470\text{pF}$  and the resistance at the FET input. If required, lowering this series capacitance (or an extra coil at the input to ground) can improve the 60Hz suppression further, at some loss of sensitivity at Long Wave.

**6.4. Optional applications:**

**Option 1. AM - SW 49m reception.**

Compared to the given MW/LW application, the main difference is that after the rf-pre-stage the signal passes a **low-pass filter** which can be for LW/MW/SW-49m a 5th order filter, see Fig.31 for a filter which passes short wave up to about 8 MHz.

This filter gives additional 10.7MHz suppression (about 55 dB by notch-filtering).



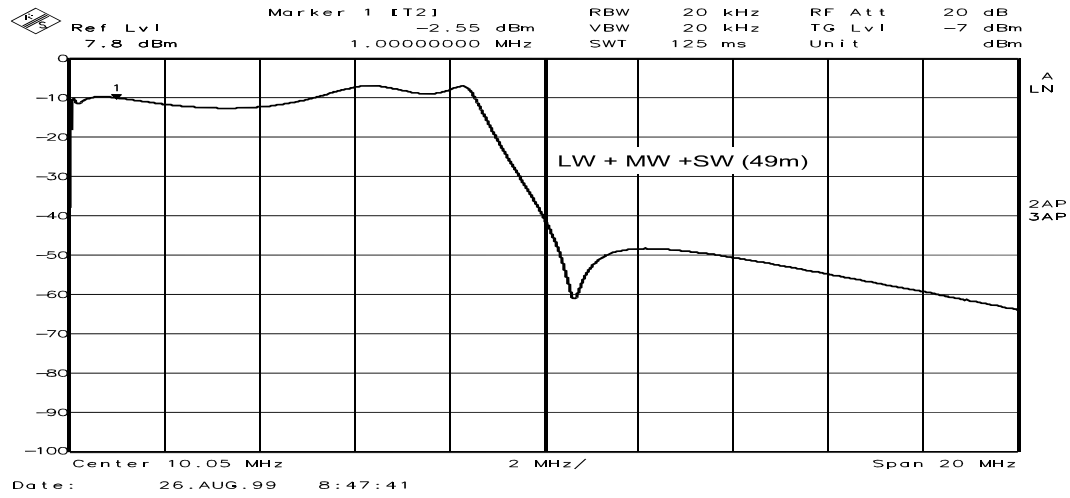

Fig.31. AM LW/MW/SW-49m 5th order Low-Pass Filter.

Moreover the VCO divider is set at 10, with the VCO in a range 166 to 169 MHz to tune 5.9 to 6.2MHz. Tuning step 1kHz, using a synthesiser ref. freq. of 10 kHz. Fig. 32 shows the S/N and distortion at 49 m.

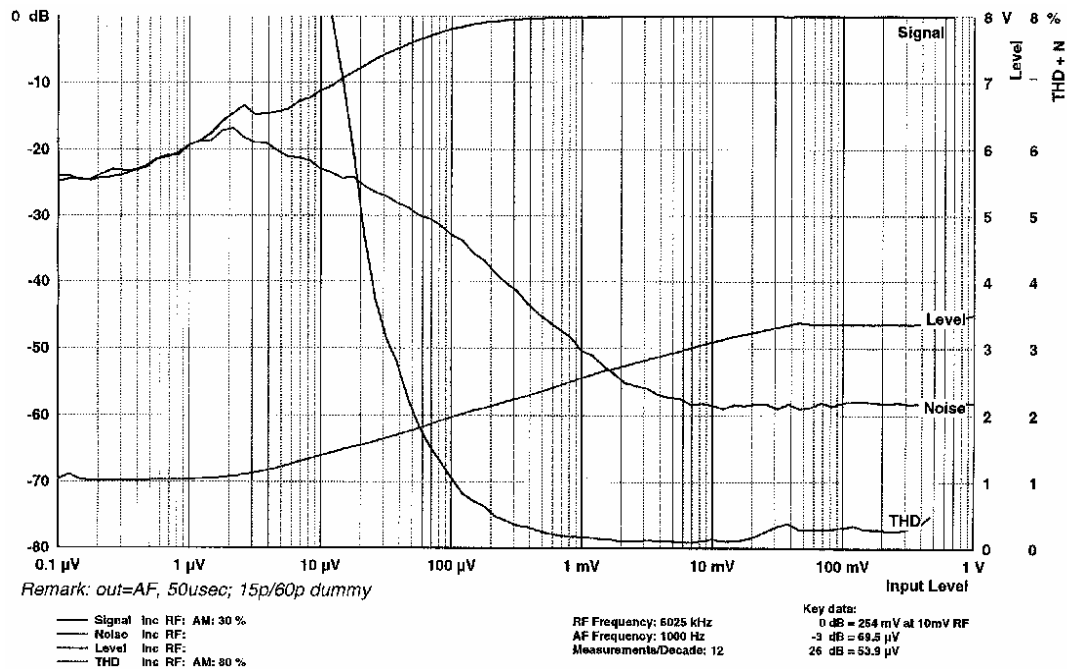

Fig. 32 AM SW - 49m Signal and noise behaviour

**Option 2. System applications.**

\* **RDS:** After FM-demodulation/ before entering the mute function, an MPX-RDS signal is available, to drive the RDS-demodulator (like SAA6579). A sensitivity of  $13\mu\text{V}$  (from  $75\Omega$ ) can be obtained; defined from 50% good blocks detection at RDS signal modulation with  $\Delta f = \pm 2\text{kHz}$ .

\* **Weather-Band (WX-mode):**

For FM Weather band applications at frequencies 162.4 to 162.55 MHz, the IC has to receive data byte 4 the bits 0,1,2 set to 011, Then the Nice concept provides:

1. delivering, at pin 31, a WX-flag for switching;
    - a. to tune the rf-input from FM- to WX-band,
    - b. to switch from FM 10.7MHz FM-IF to a narrow-band IF-selectivity,
  2. setting the divider N1 at  $N1=1$ ,  
 to use the VCO at  $(\text{WX-IF1}) = 173.1$  to  $173.25$  MHz;
  3. a quadrature phase shift network is switched in to drive the quadrature mixer, to achieve 25 dB of integrated image rejection.
  4. switching the audio-amplifier at WX to 15 times higher gain, to obtain standard a.f.-output level at the small WX-deviation
- More application information in Appendix 5

\* **Audio Signal Processors (CASP/ CDSP)**

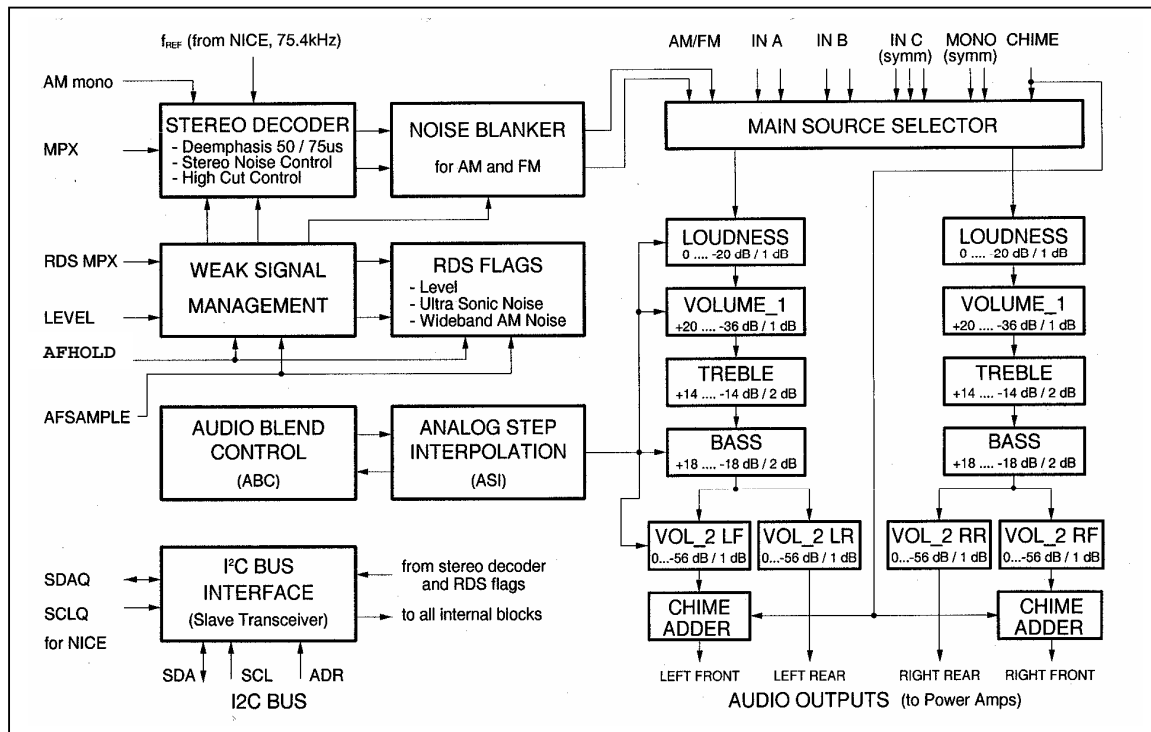

Fig. 33 CASP Functional Block-diagram

The application of NICE with Audio signal processors CASP (TEA 6880) or CDSP (SAA7709) gives extra functional advantages;

e.g. with CASP:

- For RDS updating NICE delivers AF-sample and AF-hold output, taking care that RDS update will be done with a mute according to timing and behaviour which gives no audible interferences. To that end at a start of AF-update the AF-hold switches off the audio weaksignal functions. When AF-sample arrives the audio signal processor starts detecting signal quality and at the end AF-hold gives free the audio weak signal controls and tells the processor that the outcome of the update check can be transferred by I<sup>2</sup>C-bus.
- For FM-stereo decoding NICE delivers a 75.368 kHz reference signal; pre-setting the oscillator for sub-carrier regeneration. This reference signal has been used for all other timing too.
- After a pre-cancelling of AM noise-interferences in NICE, CASP in turn cancels the rest of spikes in the AM-audio signal. (In addition CASP delivers an AMHOLD pulse to operate the gate into an external AM-stereo processor.)
- The I<sup>2</sup>C-bus interface in CASP has a I<sup>2</sup>C-bus output for NICE. As it is preferred to have the NICE-bus switched off if no NICE bus commands are asked for (such to eliminate interference risks) this can be done with one bus, both for CASP and NICE.
- For weak signal management NICE delivers AM/FM fieldstrength levels, well defined in start and slope points. Note that CASP has six signal quality detectors: noise/ fieldstrength/ multipath, and those both in average and peak detection.

*Additional functions of interest in CASP are the Rear Seat Audio source-selector and a Chime Adder circuit to sum the Chime signal with audio.*

## 6.5 DERIVATIVE PRODUCTS

### ***Functional and specification differences of NICE IC family TEA684x***

	<b>TEA6840</b>	<b>TEA6845</b>	<b>TEA6846</b>
Package	QFP_64	QFP_64	LQFP_80
Start AM inband AGC	850mV	380mV	380mV
Start AM wideband AGC	375mV	125mV	125mV
	500mV	250mV	250mV
	625mV	375mV	375mV
	750mV	500mV	500mV
AM softmute FOM	36dB	36dB	36dB
FM_IF gain	10.5dB + 4.5dB	14.5dB + 8.5dB	14.5dB + 8.5dB
Improved FM on intermodulation		x	x



Bits 4,5,6 Synthesiser ref. frequency			
Bit 4	Bit 5	Bit 6	Ref. Frequency (kHz)
0	0	0	= 100
0	0	1	= 50
0	1	0	= 25
0	1	1	= 20
1	0	0	= 10
1	0	1	= 10
1	1	0	= 10
1	1	1	= 10
Bit 7 :	IF Counter period		0 = 20 msec
			1 = 2 msec

**Byte 5 :** Test purposes:

Bit 0 and 1: Test bits : Output pin 15

Bit 0	Bit 1	
0	0	= Ref. Freq. for Audio Signal Processor
0	1	= PLL Synthesizer ref. Freq.
1	0	= Progr. divided VCO-frequency
1	1	= No output

Bit 2 : Test bit for DAA

Bit 3 : Test bit for Tri-state

0 = off

Bit 4 : AM soft mute 0 = on

Bits 5 and 6 : Wideband agc start point

At FM	Bit 5	Bit 6	
	0	0	= 375 mV
	1	0	= 500 mV.
	0	1	= 625 mV
	1	1	= 750 mV

At AM	Bit 5	Bit 6	
	0	0	= 4 mV
	1	0	= 8 mV
	0	1	= 12 mV
	1	1	= 16 mV

Bit 7 : FM Keyed AGC 0 = off

**Byte 6 : Level DAA setting**

Bits 0-2 Level slope setting

Bits 3-7 Level starting point

**3. Bytes to be transmitted**

2 bytes

**Byte 1 :** Bit 0 to 7 : IF-counter information,

LSB to MSB

Note: When the transmission to the front-end IC is disabled after the synthesizer loop has locked on a new frequency, the content of the IF-counter is available after the selected measuring time. The IF counter will be reset when the I<sup>2</sup>C-Bus logic detects the address of the IC. This disables changes in the latches for the IF-count, while reading this value.

## **APPENDIX 2: ALIGNMENTS**

The NICE tuner concept requires a number of alignments for an optimum performance:

### 1. Antenna DAA alignment.

The DAA values take care of the tracking between front-end and oscillator by applying an offset between the tuning voltage to the front-end and the tuning voltage of the oscillator circuit. Usually only three alignments are necessary and sufficient for a good tracking performance: lower band limit, upper band limit and in the centre of the band.

In the user application the proper DAA value for any given tuning frequency may be interpolated from the aligned values. When also the weather-band is included in the final application one extra alignment is required.

*The procedure to align the antenna DAA value is as follows:*

Set a generator (no modulation) to the frequency to be aligned with an RF level of about 300  $\mu\text{V}$  and also tune NICE to this frequency. Next ramp the DAA word from 0 to 127 while measuring the DC-output of the level detector of NICE for each DAA value. The proper DAA value to be stored is the DAA word where the signal level has its maximum value.

### 2. AM & FM level slope and level start.

The DC-output of the level detector is used to control the NICE tuner performance, e.g. FM Keyed AGC and AM noise canceller (plus back-end processing = weak signal behaviour, search criteria) etc. The actual small signal behaviour is controlled either by CASP (Car Analog Signal Processor) or by CDSP (Car Digital Signal Processor). For (re) production purposes the starting point of the level detector output should be aligned as well as the slope of the level detector output. These alignments require three different steps:

#### **FM:**

- The level detector output is aligned to, e.g., 950 mV at an RF input level of 3  $\mu\text{V}$ .
- The level slope is aligned in such a way that the difference in level detector output between RF levels of 20 and 200  $\mu\text{V}$  is 800 mV with the level start value found in the first alignment.
- The level detector output at 3  $\mu\text{V}$  RF level is re-aligned to 950 mV with level slope at the value found at the previous alignment.

(Note: 950mV at FM is switch-off level of keyed AGC).

#### **AM:**

- The level detector output is aligned to 2000 mV at an RF input level of ,e.g.,150  $\mu\text{V}$ .
- Dependent on backend (ASP) requirements, the level slope could be aligned, and then in such a way that the difference in level detector output between RF levels of 20 and 200  $\mu\text{V}$  is 800 mV with the level start value found in the first alignment.
- The level detector output at 150  $\mu\text{V}$  RF level is re-aligned to 2000 mV with level slope at the value found at the previous alignment.

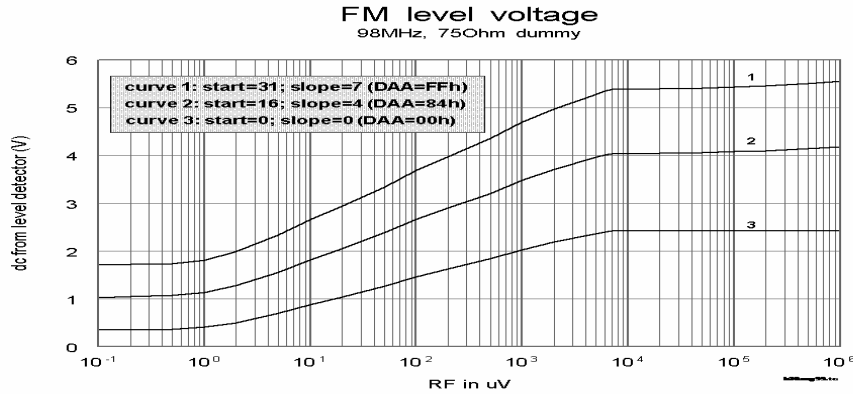
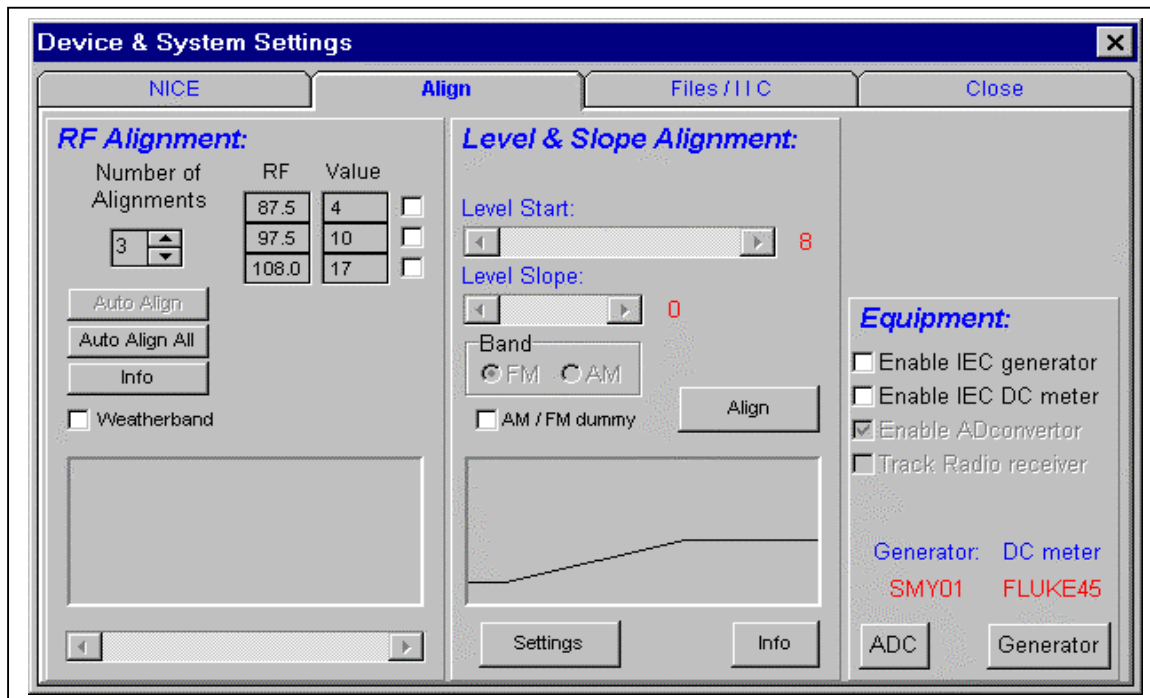

Fig. 34 FM Level Voltage

*The procedure to align the start and slope values is as follows:*

Initially set level slope to 7 and level start to 31 and tune NICE to 97.5 MHz (990 kHz for AM). Set the frequency generator to 97.5 MHz (990 kHz for AM) without modulation. In the first alignment the level start is ramped down until the proper level detector output has been found (950 mV at 3  $\mu$ V RF level / 2000 mV at 150  $\mu$ V RF level for AM). In the second alignment the level slope is ramped down until the difference in signal level output between 20 and 200  $\mu$ V RF level is 800 mV (both for FM and AM). Finally the level start value is realigned to 950 mV at 3  $\mu$ V RF level or 2000 mV at 150  $\mu$ V RF level for AM.

Note: Normally the AM slope alignment is of no importance for the performance of the NICE system, so this alignment could be skipped all together and the slope may be set to e.g. 0 in the final application.



**APPENDIX 3. MODULE**

**a. Module PCB**

**Fig. 35**





b. Module application diagram

Fig. 36

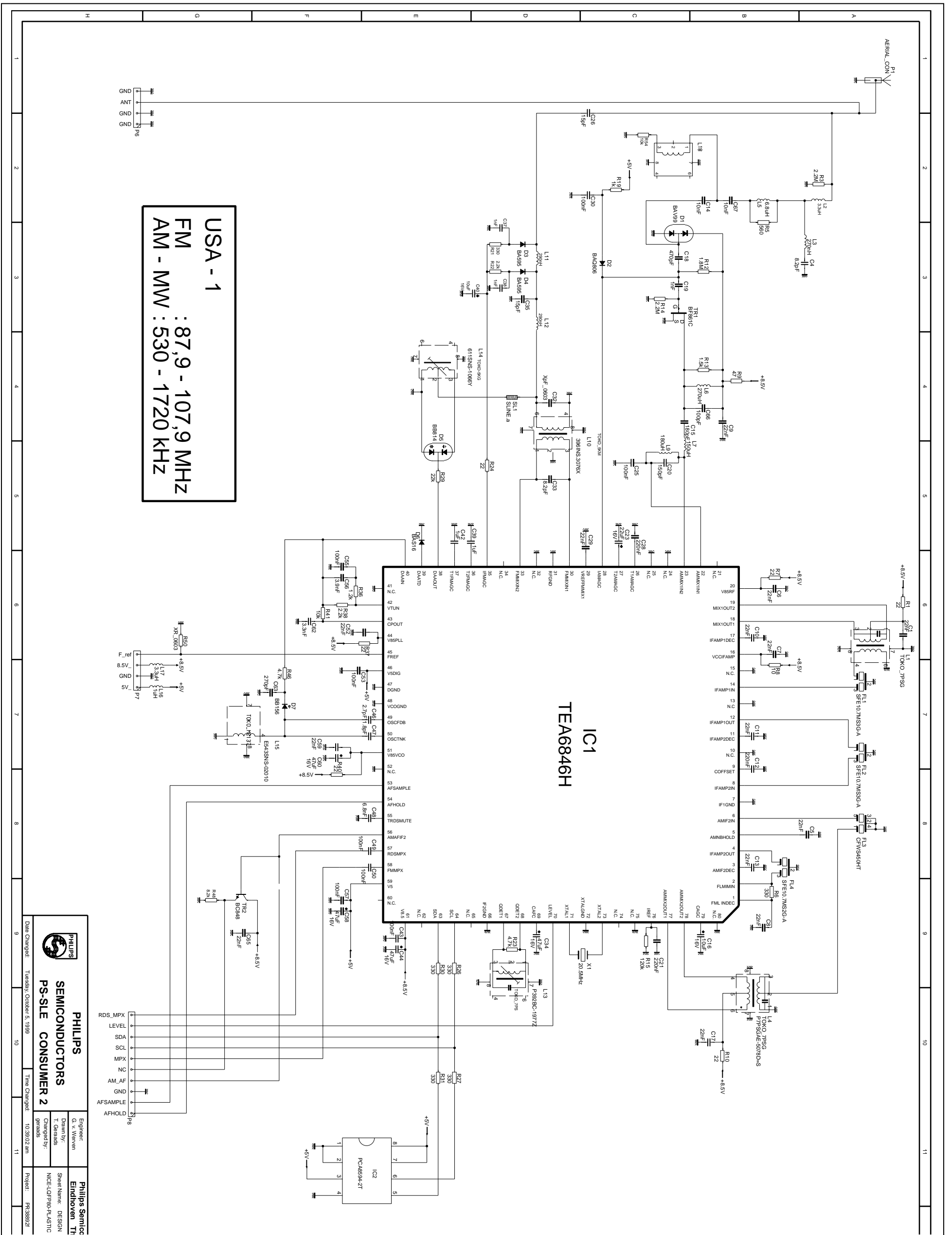

USA - 1  
 FM : 87,9 - 107,9 MHz  
 AM - MW : 530 - 1720 KHZ

**PHILIPS SEMICONDUCTORS PS-SILE CONSUMER 2**

PHILIPS SEMIc  
 Eindhoven Th

Engineer: G. v. Waveren  
 Drawn by: T. Garasds  
 Checked by: NICE-LOFP98-PLASTIC  
 Project: PR38892Z

Date Changed: Thursday, October 5, 1998  
 Time Changed: 10:30:02 am

### c. COMPONENTS

From the NICE-Module with TEA6846H, acc. to the given application, the components are:

#### Bill Of Materials of Project: PR38892E Last Update: 1999/05/17 - 12:37h

QNT	PART_NO	COMPONENT	SERIES	TOLERANCE	RATING	VENDOR	GEOMETRY	REFERENCE
1	1	8222-411-38892	BOARD PR38892			PS-SLE	BOARD	
2	1	CAP-CER-603-pF	XpF_0603	C0603-X7R	10%	63V	PHILIPS	C0603 C32
3	1	2222-960-16654	220nF	X7R	10%	16V	PHILIPS	C0805 C28
4	2	2222-910-19854	220nF	Y5V	N20/P80	25V	PHILIPS	C0805 C12 C21
5	2	2222-861-12102	1nF	NP0	5%	50V	PHILIPS	C0805 C37 C38
6	1	2222-861-12271	270pF	NP0	5%	50V	PHILIPS	C0805 C63
7	1	2222-861-12471	470pF	NP0	5%	50V	PHILIPS	C0805 C18
8	2	2222-882-16663	1uF	X7R	10%	25V	PHILIPS	C1210 C39 C42
9	2	2222-134-35109	10uF	RLP5 134	20%	16V	PHILIPS	CASE_R52_TFA C16 C40
10	1	2222-134-55229	22uF	RLP5 134	20%	16V	PHILIPS	CASE_R54_CA C23
11	4	2222-134-55479	47uF	RLP5 134	20%	16V	PHILIPS	CASE_R55_CA C34 C44 C58 C60
12	1	2222-596-16604	180pF	X7R	10%	50V	PHILIPS	C0603 C15
13	1	2222-596-16614	1nF	X7R	10%	50V	PHILIPS	C0603 C19
14	1	2222-596-16621	3.3nF	X7R	10%	50V	PHILIPS	C0603 C62
15	1	2222-596-16622	3.9nF	X7R	10%	50V	PHILIPS	C0603 C56
16	1	2222-596-16625	6.8nF	X7R	10%	50V	PHILIPS	C0603 C48
17	2	2222-596-16627	10nF	X7R	10%	50V	PHILIPS	C0603 C14 C67
18	6	2222-916-16741	22nF	X7R	20%	25V	PHILIPS	C0603 C5 C7 C8 C10 C11 C13
19	8	2222-786-16749	100nF	X7R	20%	16V	PHILIPS	C0603 C25 C30 C43 C49 C50 C53 C55 C57
20	8	2222-586-18807	22nF	Y5V	N20/P80	50V	PHILIPS	C0603 C1 C6 C9 C17 C29 C52 C59 C65
21	1	2222-867-12101	100pF	NP0	5%	50V	PHILIPS	C0603 C66
22	1	2222-867-12151	150pF	NP0	5%	50V	PHILIPS	C0603 C20
23	2	2222-867-12159	15pF	NP0	5%	50V	PHILIPS	C0603 C26 C35
24	1	2222-867-12188	1.8pF	NP0	0.25pF	50V	PHILIPS	C0603 C47
25	1	2222-867-12278	2.7pF	NP0	0.25pF	50V	PHILIPS	C0603 C46
26	2	2222-867-12828	8.2pF	NP0	0.5pF	50V	PHILIPS	C0603 C4 C33
27	1	PN-BAQ806	BAQ806	Pin_diode			PHILIPS	SOD106 D2
28	1	9332-153-70212	BAV99	Gen.Purpose			PHILIPS	SOT23 D1
29	1	PN-BB156	BB156	TunerDiode			PHILIPS	SOD323 D7
30	1	9334-606-20212	BAS16	Gen.Purpose			PHILIPS	SOT23 D6
31	2	Q62702-A952	BA595	Pin_diode			SIEMENS	SOD323 D3 D4
32	1	Q62702-B372	BB814	TunerDiode			SIEMENS	SOT23 D5
33	1	CFWS450HT	CFWS450HT	IF-Filter			muRata	SFR450H FL3
34	1	SFE10.7MS3	SFE10.7MS2G-A	IF-Filter			muRata	SFE_3p FL4
35	2	SFE10.7MS3	SFE10.7MS3G-A	IF-Filter			muRata	SFE_3p FL1 FL2
36	1	PN-PCA8594-2T	PCA8594-2T	IC_Universal			PHILIPS	SOT96 IC2
37	1	PN-TEA6846H	TEA6846H	IC_Universal			PHILIPS	SOT315 IC1
40	1	LAL02NA151K	150uH	LAL02NA	10%		TAIYO_YUDEN	uChoke_2e L7

**TEA 6840H A NICE RADIO**  
**for New In Car Entertainment**

**APPLICATION NOTE**  
**AN 99040**

41	1	LAL03NA181K	180uH	LAL03NA	10%		TAIYO_YUDEN	uChoke_3e	L9
42	1	LAL02NA1R0K	1uH	LAL02NA	10%		TAIYO_YUDEN	uChoke_2e	L16
43	1	388BN-1211Z	388BN-1211Z	7PS			TOKO	7PD_1	L16
44	1	LAL03NA271K	270uH	LAL03NA	10%		TAIYO_YUDEN	uChoke_3e	L6
45	1	P826RC-5134N=S	P826RC-5134N=S	7PS			TOKO	7PS_p2	L1
46	2	LAL02NA3R3K	3.3uH	LAL02NA	10%		TAIYO_YUDEN	uChoke_2e	L2 L17
47	1	LAL02NA6R8K	6.8uH	LAL02NA	10%		TAIYO_YUDEN	uChoke_2e	L5
48	2	LQN1HR29K04	290nH	LQH			muRata	LQH1n	L11 L12
49	1	TOKO-5KM	396INS.3076X	5KM			TOKO	TOKO_5km	L10
50	1	TOKO-7KM	P392BC-1977Z	7KM			TOKO	TOKO_7km	L13
51	1	TOKO-5KM_m2	611SNS-1066Y	5KM			TOKO	TOKO_5KM_m2	L14
52	1	TOKO-7KM_m2_m5	P7PSGAE-5078D=S	7KM			TOKO	TOKO_7km_m2_m5	L4
53	1	LAL02NAR27K	270nH	LAL02NA	10%		TAIYO_YUDEN	uChoke_2e	L3
54	1	E543SNAS-02010	E543SNAS-02010	MC137			TOKO	MC137	L15
58	1	RES-704-R0603	XR_0603	RC11	1%	0.1W	PHILIPS	R0603	R50
59	1	2322-730-61102	1k	RC11	5%	0.1W	PHILIPS	R0805	R19
60	2	2322-702-60103	10k	RC21	5%	0.063W	PHILIPS	R0603	R41 R54
61	1	2322-702-60109	10	RC21	5%	0.063W	PHILIPS	R0603	R8
62	1	2322-702-60122	1.2k	RC21	5%	0.063W	PHILIPS	R0603	R36
63	1	2322-702-60124	120k	RC21	5%	0.063W	PHILIPS	R0603	R15
64	1	2322-702-60152	1.5k	RC21	5%	0.063W	PHILIPS	R0603	R13
65	1	2322-702-60185	1.8M	RC21	5%	0.063W	PHILIPS	R0603	R12
66	2	2322-702-60222	2.2k	RC21	5%	0.063W	PHILIPS	R0603	R22 R38
67	1	2322-702-60223	22k	RC21	5%	0.063W	PHILIPS	R0603	R29
68	2	2322-702-60225	2.2M	RC21	5%	0.063W	PHILIPS	R0603	R3 R14
69	6	2322-702-60229	22	RC21	5%	0.063W	PHILIPS	R0603	R1 R7 R10 R24 R37 R40
70	6	2322-702-60331	330	RC21	5%	0.063W	PHILIPS	R0603	R6 R21 R26 R27 R30 R31 R23 R46
71	2	2322-702-60472	4.7k	RC21	5%	0.063W	PHILIPS	R0603	
72	1	2322-702-60479	47	RC21	5%	0.063W	PHILIPS	R0603	R9
73	1	2322-702-60561	560	RC21	5%	0.063W	PHILIPS	R0603	R5
74	1	2322-702-60822	8.2k	RC21	5%	0.063W	PHILIPS	R0603	R48
76	1	9335-896-10215	BC848	Gen_Purpose			PHILIPS	SOT23	TR2
77	1	LN-G102-587	20.5MHz	Crystal			NDK	HC49_u13	X1
78	1	9340-344-00215	BF861C	FET			PHILIPS	SOT23	TR1

**APPENDIX 4**

**TEA6840H Module Specification**

In a Car Radio application (see Fig. 36) TEA 6840H performs typical as given in next specification.

**AM reception:**

At  $F_a$  = 530 to 1710 kHz,  
 and at  $F_{if1}$  = 10.7 MHz,  
 $F_{osc1}$  = 11.23 to 12.41 MHz, obtained via divider  $N2 = :20$ , so  
 $F_{vco}$  = 224.6 to 248.2 MHz.  
 With  $F_{if2}$  = 450 kHz,  
 $F_{osc2}$  = 10.25 MHz, obtained via a divider  $N = :2$   
 from  
 X-tal osc = 20.5 MHz.

**FM reception:**

At  $F_a$  = 87.5 to 108 MHz,  
 and at  $F_{if1}$  = 10.7 MHz,  
 $F_{vco}$  = 196.4 to 237.4 MHz.

**RATINGS**

Parameter	min	typ	max	unit
Supply Voltage: Operation	10		15	Volt
Supply Voltage: Performance	8.1		8.9	Volt
Temperature : Operating	-40		+85	°C

**AM-SIGNAL-CHANNEL.**

Test with dummy aerial **15/60pF** from 50 Ohm source

Conditions (a.o. for standard output), unless otherwise specified :

$V_a$ : 10 mV,  $F = 1$  MHz,  $f_{mod} = 400$  Hz,  $m = 0.3$ ;

$V_{supply} = 8.5$  Volt/  $T_{amb.} 25^\circ\text{C}$

**AM Performance:**

	Typ.	Unit
<b>1. Sensitivity</b>		
Signal to Noise at $V_a = 10 \mu\text{V}$	: 10	dB
Signal to Noise at $V_a = 55 \mu\text{V}$	: 26	dB
<b>2. AM-Signal to noise ratio</b>		
Signal to Noise at $V_a = 10$ mV	: 60	dB
<b>3. A.F. output at <math>m=30\%</math></b>	: 250	mV
<b>4. Figure of Merit at soft mute on</b>		
$\Delta V_{out\_a.f.}$ at $V_a = 10 \mu\text{V}$ to 5 mV	: 13	dB
<b>5. Distortion (THD) at <math>m=0.8</math></b>	: 0.3	%

**TEA 6840H A NICE RADIO  
for New In Car Entertainment**

**APPLICATION NOTE  
AN 99040**

<b>Further AM-performance:</b>		<b>Typ.</b>	<b>Unit</b>
<b>6. Selectivity <math>S_9</math></b>	:	70	dB
<b>7. Dyn.Selectivity;</b>	:	73	dB
$V_{ref} = V_{out}$ at standard mod. of $V_{a1}$ . When $V_{a1}$ has $m=0$ and $F_{a2} = F_{a1} + 20\text{kHz}$ resp $-20\text{kHz}$ ; $m=30\%$ 1kHz, $V_{a2}/V_{a1}$ at $V_{out} = V_{ref} - 10\text{dB}$			
<b>8. IF-rejection</b> (at 600kHz); $F_a = \text{IF1}$	:	85	dB
$F_a = \text{IF2}$	:	77	dB
<b>9. Image rejection</b> (at 1600kHz) $F_a + 2*IF1$	:	71	dB
$F_a + 2*IF2$	:	76	dB
<b>10. Second Harmonic Rejection</b>	:	49	dB
Tuned at 1340 kHz for $V_{out1}$ at $m=30\%$ ; $V_{a2}$ ( $m=30\%$ ) for $V_{out2} = V_{out1}$ at $F_{a2} = 670$ kHz.			
<b>11. Large signal handling</b>	:	>140	dB $\mu$ V
at THD=10% where $m=80\%$ .			
<b>12. Intermodulation IP3 for in-band interference</b>	:	130	dB $\mu$ V
(interfering transmitters at $\pm 100\text{kHz}$ offset)			
<b>13. Desensitization at <math>V_a=1\text{Volt}</math></b>	:	19	dB
for $F_{a2} = F_{a1} - 40\text{kHz}$ at $F_{a1} = 1310\text{kHz}$			
<b>14. FM to AM switching time</b>	:	1	sec

**FM-SIGNAL-CHANNEL**

Test with 50 Ohm (gen.) + dummy aerial = **75 Ohm** source.

Test conditions, unless otherwise specified :

$V_i$  : 1 mV<sub>rms</sub>,  $F_a = 98$  MHz,

mono with  $f_{mod} = 400$  Hz,  $\Delta f = \pm 22.5$  kHz. De-emphasis 50  $\mu$ sec.

$V_{supply} = 8.5$  Volt/  $T_{amb.} = 25^\circ\text{C}$

**FM PERFORMANCE**

**1. Sensitivity**

at  $\Delta f = \pm 75\text{kHz}$

- Signal to Noise ratio at  $V_a = 2 \mu\text{V}$

**2. Signal to noise ratio**

- S/N at  $V_a = 1$  mV

**3. A.F. output** at  $\Delta f = \pm 22.5$  kHz

**4. Distortion (THD)** at  $\Delta f = \pm 75\text{kHz}$

**5. AM signal suppression** ( $m=0.3$ )

Typ. Unit

: 26 dB  
 : 65 dB  
 : 210 mV  
 : 0.6 %  
 : 60 dB

Further FM-Performance:

	Typ.	Unit
<b>6. -3dB limiting</b> at $V_i$	1.7	$\mu\text{V}$
<b>7. Selectivity S+/-200</b>	70	dB
<b>8. IF-rejection</b> (at 87.9MHz);	75	dB
<b>9. Image rejection</b> (at 107.9MHz)	70	dB
<b>10. Fieldstrength dc-level info range</b>	80	dB
<b>11. Adjacent Channel Selectivity</b>	67/63	dB
Standard signal at $V_{a1}=100\mu\text{V}$ as reference, than unmodulated and $F_{a2}$ at + resp.-200kHz, causing a S/N=30dB at a ratio $V_{a2}$ to $V_{a1}$		
<b>12. Intermodulation IP3</b>	117	dB $\mu\text{V}$
<b>13. Desensitization</b> on limiting sensitivity by $F_{a2}= F_{a1}+1.5\text{MHz}$	34	dB
<b>14. PLL In-lock time</b> 108 to 88 MHz	0.8	msec

**APPENDIX 5**

**Weather-band Receiver**

The weather-band as currently in operation in the USA consists of a nation-wide network of radio stations broadcasting continuous weather information direct from various (local) stations throughout the US for general public use. The network is provided as a public service by the National Oceanic & Atmospheric Administration (NOAA), and as such it is controlled by the federal government. When necessary, warnings, watches and other hazard information can be broadcast for the region involved in addition to weather forecasts. Broadcasts are found at seven (narrow-band FM modulated) voice channel frequencies ranging from 162.400 MHz to 162.550 MHz.

A weather-band receiver with NICE has demonstrated to be feasible with a minimum number of additional components. Especially the possibility to utilise a ceramic narrow-band IF filter provides a cost-effective solution. The performance of a receiver using such a filter was compared to a NICE receiver using a more expensive crystal IF filter as used more traditionally in narrow-band FM applications. The sensitivity achieved with a NICE module including a crystal filter is 1.8  $\mu$ V for 20dB S/N ratio, whereas the ceramic filter version shows a sensitivity of 2.5  $\mu$ V.

**Weather-band**

Frequency	162.4 to 162.55 MHz
Modulation	Narrow Band FM (NBFM)
Deviation	$\Delta f$ nominal = $\pm 1.5$ kHz ( $\Delta f$ maximum = $\pm 5$ kHz)
De-emphasis	Approx. 135 $\mu$ sec

**Weather-band reception with the TEA6840H**

The NICE IC TEA6840H has several on-board provisions for the reception of the weather-band. The NICE IC utilises the signal path used for the standard broadcast FM band also in weather-band mode. This means the IF is at 10.7MHz, the local oscillator operates at 173.1 to 173.25 MHz.

When programmed through the I2C bus to switch to weatherband reception:

1. a weatherband flag is set, indicating to the external circuit to switch
  - a. the front end filter to the weatherband frequency;
  - b. to a narrow band IF filter
2. internally, the local oscillator divider is switched off (division ratio one)
3. a quadrature phase shift network is switched in to drive the quadrature mixer with image cancelling;
4. the MPX amplifier/buffer following the FM demodulator is switched to a fifteen times higher gain, otherwise the demodulated FM signal level when receiving the weatherband should be smaller than the demodulated wideband FM signals, due to the frequency deviation of the narrow band FM signals in weatherband.

Ad 1. WX-flag

Pin 31 of the TEA6840H NICE IC provides the weatherband flag signal. The voltage on this pin is fixed at about 4.85 V when the NICE switches into weatherband mode. (At AM the voltage remains under 4 V.)

For switching this flag signal can be converted to a logic line designated 'WB' and its logic inverse signal 'WBnot'.

- a. Front-end: The 'WB' is used to switch a coil in parallel with the LC resonant circuit consisting to move the tank resonant frequency to about 162 MHz.
- b. IF-filter switching: The allocation of the frequencies for the (neighbouring) transmitter stations is such that adjacent channel interference is hardly anywhere present in the USA. This means a larger bandwidth for the IF filter is tolerable. It is indeed of more importance, judging from the frequency allocation scheme, that the rejection at the next adjacent channel (at twice the channel spacing: 50 kHz) is sufficient. The IF filter need not be an expensive crystal filter in this case; a ceramic filter, e.g. SFE 10.7 MFP, can be chosen. The bandwidth (-3 dB) of this filter is about 30 kHz.

The input and output impedance of this ceramic filter is 600 Ohm, which is different from the 300 Ohm impedance as used by standard 10.7 MHz filters, so, at switching from FM-IF to WX-IF, optimum performance goes at the cost of additional components for impedance matching.

A 2<sup>nd</sup> order filter with a low pass response (-3 dB point) at about 1200 Hz can serve de-emphasis and limit the audio bandwidth, thereby increasing the S/N ratio and enhancing the audibility of the speech information.

**Performance:**

The following characteristics are measured with a 75 Ω dummy antenna;

$f_{af} = 1$  kHz;  $\Delta f = \pm 1.5$  kHz; AF double pole filtering with -3dB at 1200 Hz.

Wideband FM AGC threshold is set to 4 mV.

Sensitivity for 20 dB S/N	2.5 μV	(1.8 μV at x-tal filter application)
Image rejection ratio	43.5 dB	
Distortion at $\Delta f = \pm 5$ kHz	< 0.5 % for $U_{in} > 10$ μV	(<3% at x-tal filter application)
Selectivity (static)		
+/- 50 kHz	> 20 dB	(>40 dB at x-tal filter application)
+/- 75 kHz	> 40 dB	
AM suppression	> 25 dB	
IF rejection	86 dB	